



BOOM TRUCK OPERATOR SAFETY TRAINING



SAMPLE

BEING A PROFESSIONAL

- **ATTITUDE**
- **TEAM MEMBER**



OBJECTIVE: To encourage each participant to view themselves as a professional.

1. Have the class members suggest various characteristics of a professional. This need not relate only to crane operations. Make a list of suggestions on a board.
2. When making this list, do not discount any suggestion. All are important.
3. Commonly suggested characteristics are: Skill, knowledge, communications, training, experience, and patience.
4. Emphasize that ATTITUDE is a key characteristic. A person may not be skilled or have a lot of experience but with the proper attitude can conduct themselves as a professional and therefore create a safe working environment.
5. OSHA estimates that in 9 out of 10 accidents, attitude played a significant role. The individual did what he shouldn't have or didn't do what he should have.
6. Team work is an important characteristic also. A professional works for the good of the team and not just for himself. Discuss how team work can be developed in a working group.



**BOOM TRUCK
STRUCTURE
&
INSPECTION**



SAMPLE

BOOM TRUCK COMPONENTS

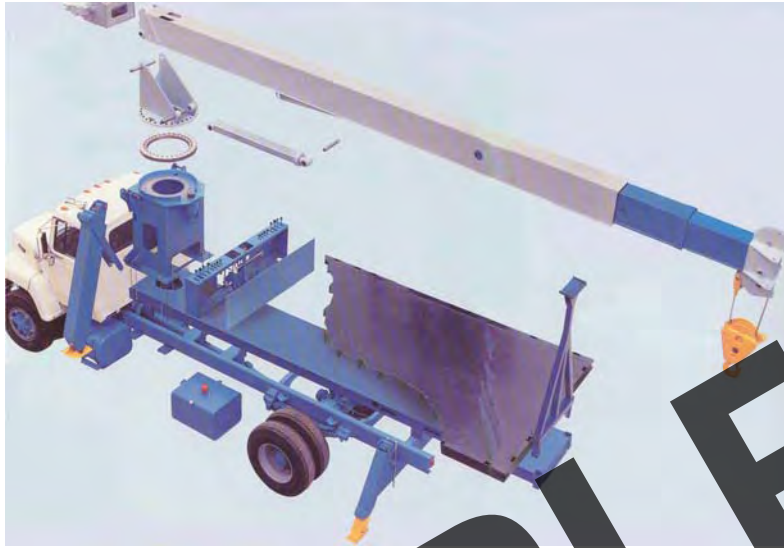

OBJECTIVE: To discuss the different components on the boom truck.

SAMPLE

BOOM TRUCK INSPECTION CHECK LIST

INSPECTION AREA	INSPECTION RESULTS			Comments
	Sat.	Unsat.	N/A	
Carrier				
Engine Oil				
Radiator				
Suspension				
Tires				
Wheels				
Rotation System				
Outriggers				
Mounting Bolts & Welds				
Hydraulic Fluid Levels				
Carrier Structure				
Oper. Station & Turret				
Gauges				
Controls & Labels				
Hydraulic Cylinders				
Hydraulic Hoses				
Warning Alarms				
Service Brakes				
Swing Brakes				
Electrical System				
Safety Equipment				
Boom				
Sheaves				
Wire Rope				
Hook & Swivel				
Boom Angle Indicator				
Load Indicators				
Anti-Two-Block System				
Winch				
Slide Pads				
Deformations, Cracks				
Boom Extension				
Load Block				



OBJECTIVE: To present the inspection checklist to the students.

1. The inspection checklist is introduced now so that the students can refer to it during the discussions regarding the mechanical structure of the crane.
2. Review briefly the items on the checklist but do not go into any detail at this time.

STABILIZER SECTION



SAMPLE

STABILIZER SECTION

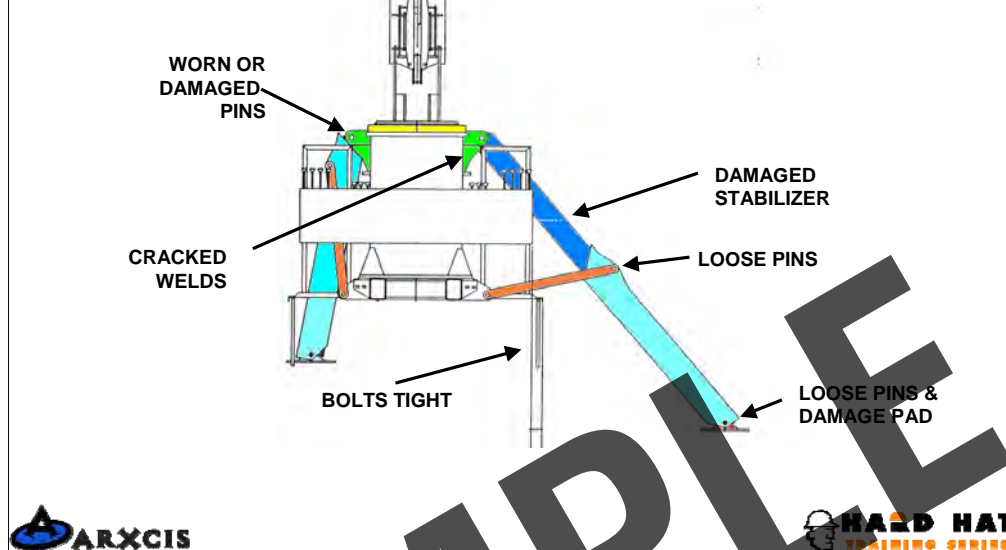

OBJECTIVE: To review the structure components which make up the stabilizer section of the crane.

1. When the stabilizer is deployed it should extend smoothly.
2. Check for any dents or deformity in the box tubes.
3. The pads should not be bent up on the corners and should move freely on the hinge pin. Check to see that the pin keepers are present and that there is no excessive play in the pin area.
4. The upper hinge pin and bushing can be check by lowering the stabilizer within a few inches of the ground and moving it back and forth. There will be some movement but excessive wear in this area needs to be repair. Excessive wear will allow the crane to rock for and aft when making a lift and cause further damage.
5. All welds associated with the structure need to be check for cracks.
6. The attachment of the crane to the truck chassis needs to be checked. If bolted, check around the bolt heads and washer area to see if there is cracked paint or dirt which could indicate movement.

TURRET SECTION



SAMPLE

TURRET SECTION

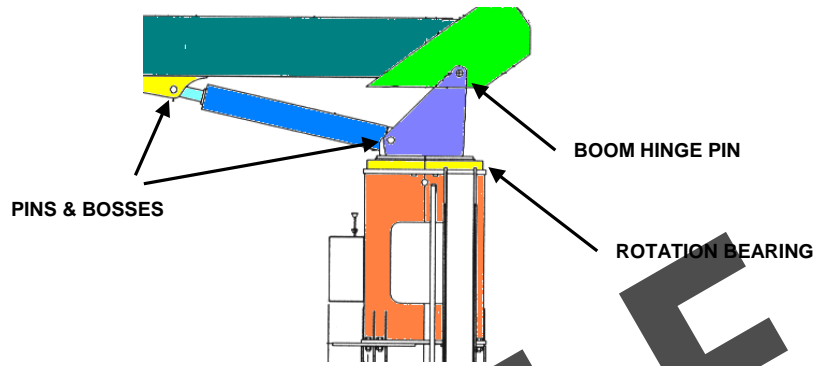

OBJECTIVE: To review the turret section inspection areas.

1. The four areas identified in the slide can be checked by performing the following functional test.
 - A. Set up the crane on level ground with the stabilizers fully extended.
 - B. Retract the boom fully.
 - C. Raise the boom to its most vertical position and extend the hoist wire about 10 feet.
 - D. Abruptly lower the boom momentarily which will result in the turret and boom component rocking. Observe the vertical movement in the rotation bearing, boom hinge pin and bushing, and the lift cylinder pins and bushings. CAUTION: WHEN SHAKING THE CRANE, OBSERVE THE HOOK AND STOP ANY BOOM MOVEMENT IF IT CAN SWING INTO THE BOOM..
2. Any excessive movement must be noted and evaluated per manufacturer's specifications.
3. Check the turret area for cracked welds and any deformed components.

ROTATION BEARING & DRIVE



SAMPLE

ROTATION BEARING & DRIVE

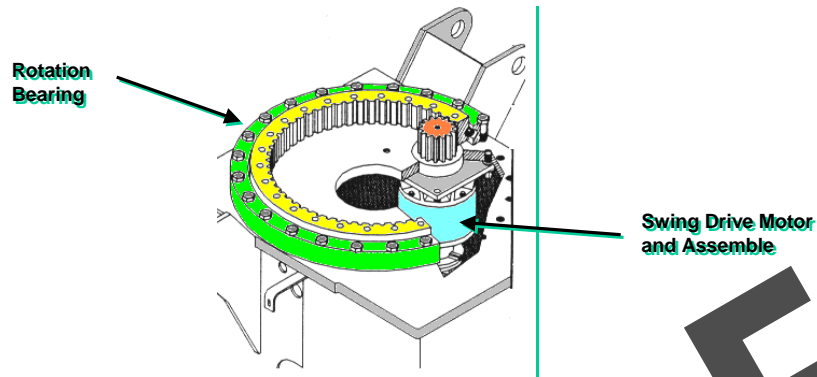

OBJECTIVE: To review the rotation bearing and drive assembly.

1. The rotation bearing is attached to the pedestal by bolts. These need to be checked for tightness. The turret is also attached to the bearing with bolts and they also need to be checked.
2. The rotation drive motor is typically mounted up in the pedestal and the mounting bolts need to be checked.
3. Check the ring and pinion gears for grease.
4. The rotation bearing should be greased on a regular basis per the maintenance manual.

ROTATION BEARING

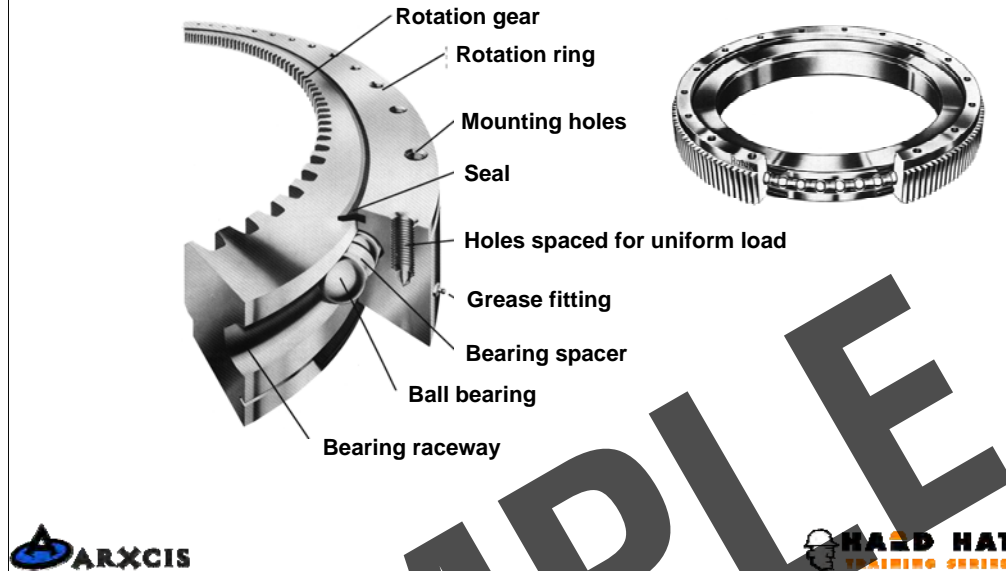

OBJECTIVE: To show the students how the rotation bearing is assembled and the importance of inspection and maintenance.

1. Point out that the turret which is attached to one half of the bearing is held in place by the ball bearings only. There are not safety hooks to prevent the turret and boom from falling if the bearing failed.
2. Review the different parts of the bearing.

BOOM & TURRET INSPECTION

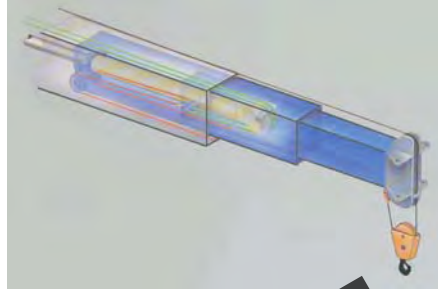

SAMPLE

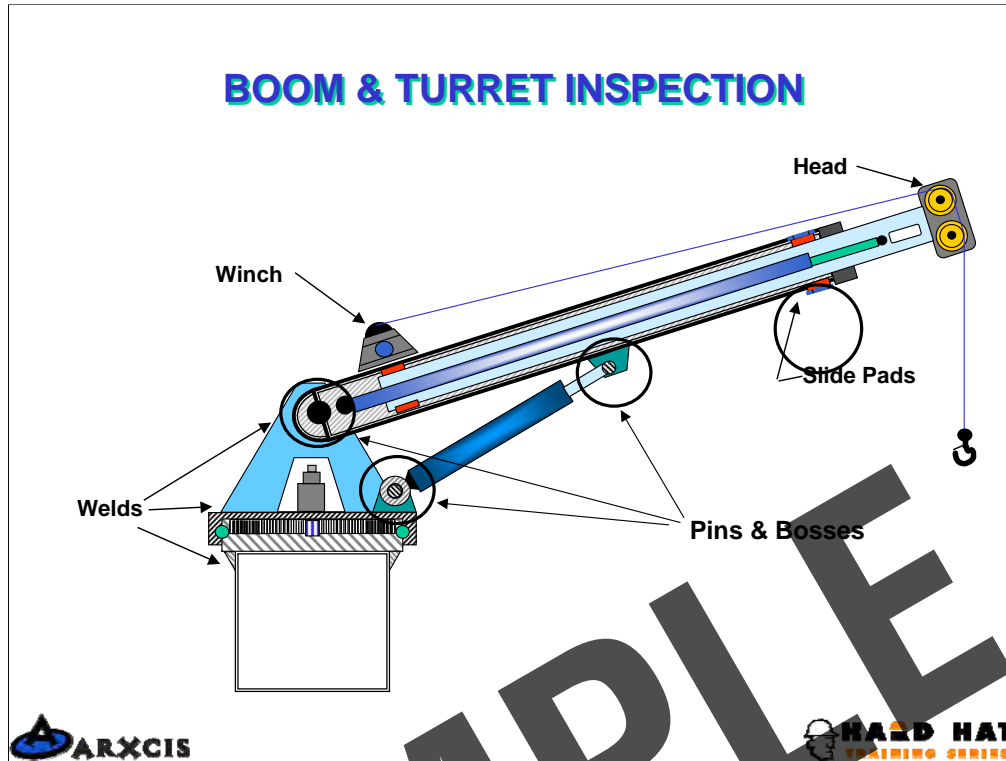

OBJECTIVE: To do an overview of the whole crane components.

1. Use this slide to discuss the parts of the crane that have not been covered yet.
2. All welds need to be checked for cracks.
3. The boom needs to be extended and check for smoothness of operation. Any binding or difficulty in extending could be the result of damaged boom sections.
4. Any hydraulic leaks need to be investigated and repaired. Check the hoses for chaffing and damage.
5. The slide pads can be checked for proper alignment by extending the boom completely and lowering the tip toward the ground. Move the boom tip back and forth by pushing on it and observing how much the boom sections move inside each other. Excessive movement will require the slide pads to be adjusted or replaced.
6. The boom tip needs to be checked to deformation and twisting.
7. The next few slides provide more details.

WINCH



CAREFULLY
MONITOR
REEVING



OBJECTIVE: The spooling of the wire rope on the winch needs to be monitored regularly to prevent damage.

1. One of the most common causes of damaged wire rope on boom trucks is from crushing due to spooling problems.
2. The operator needs to monitor the winch to prevent the wraps from loosing and allowing the wire rope to cross over itself.
3. Loosely wrapped wire rope needs to be un-spooled and then re-spooled on the winch properly to prevent damage.

INSPECTING SHEAVES

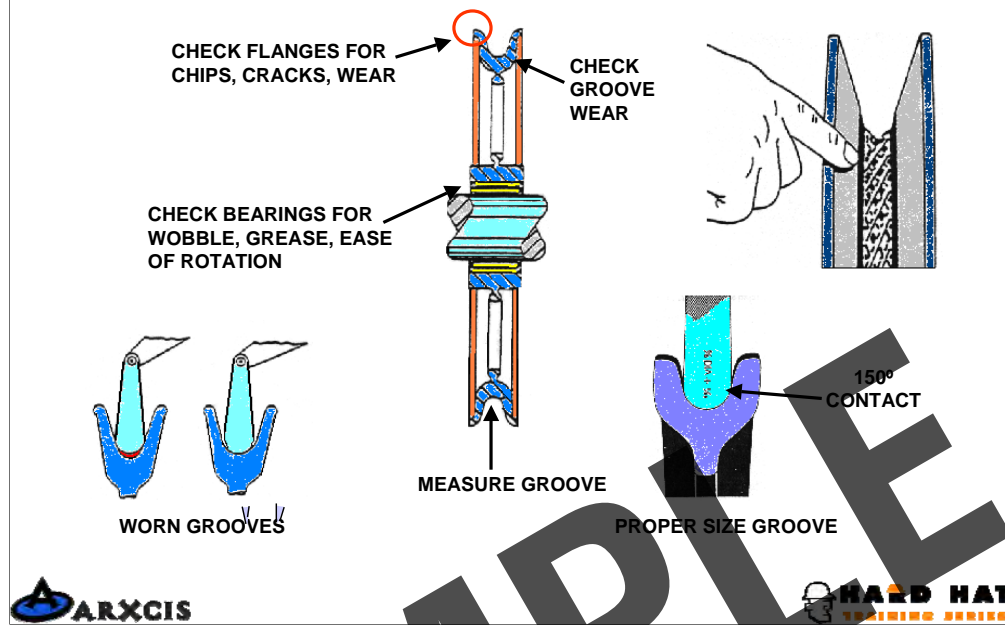

OBJECTIVE: Review the inspection of the sheaves.

1. Check for bearing wear and lubrication.
2. Check the flanges and treads.
3. Show how to use a sheave gauge.
4. Sheaves can only be repaired per manufacture's procedures.

HOOK INSPECTION

CHECK FOR:

- ✓ Wear
- ✓ Deformation
- ✓ Cracks & Sharp Nicks
- ✓ Modifications
- ✓ Safety Latches
- ✓ Swivel Wear & Lubrication
- ✓ Hook Shackle Housing

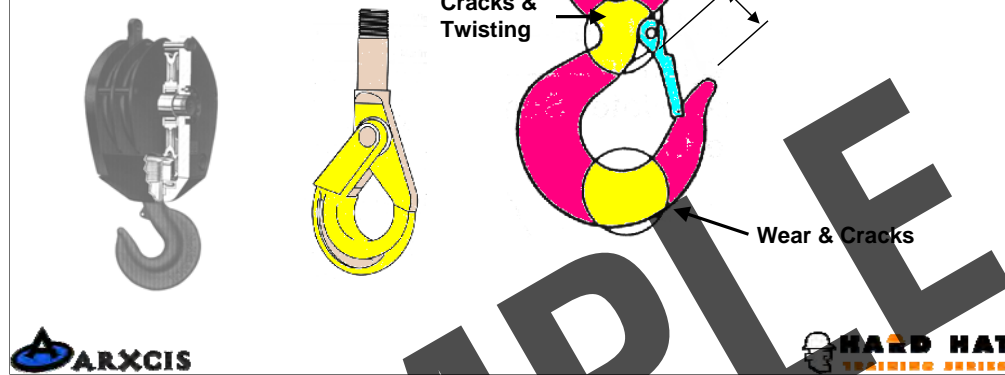

OBJECTIVE: Point out inspection areas for different types of hooks and blocks.

1. Hooks with threads and nuts need to have threads inspected periodically.
2. Hooks can only be repaired per manufacturer's procedures.
3. Wear in excess of 5% in the neck of the hook and 10% in other areas including the bow of the hook is cause for removal.
4. An increase in the hook throat opening of more than 15% is cause for removal.
5. Any twist in the hook of more than 10% is cause for removal.
6. The hook safety latch should be present and function properly.

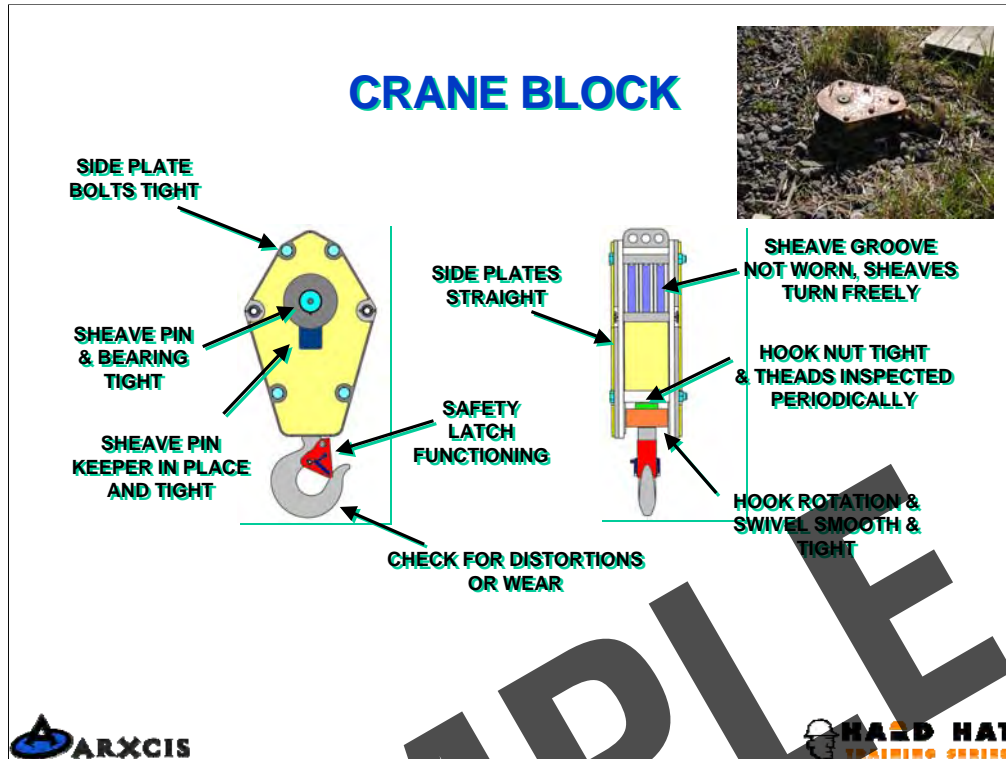

OBJECTIVE: To review the inspection criteria for hook blocks.

1. The sheaves and bearings need to be inspected as discussed earlier.
2. The side plates and any additional weights attached to their sides need to be inspected for loose or missing bolts or other fasteners.
3. The hook should rotate freely on the swivel bearing. Check for excessive movement.
4. The hook shank and nut should be separated periodically and the threads inspected for corrosion and other damage. The loss of more than 20% of the treaded area due to corrosion is cause for removal.
5. The safety latch must be in place and functioning properly.

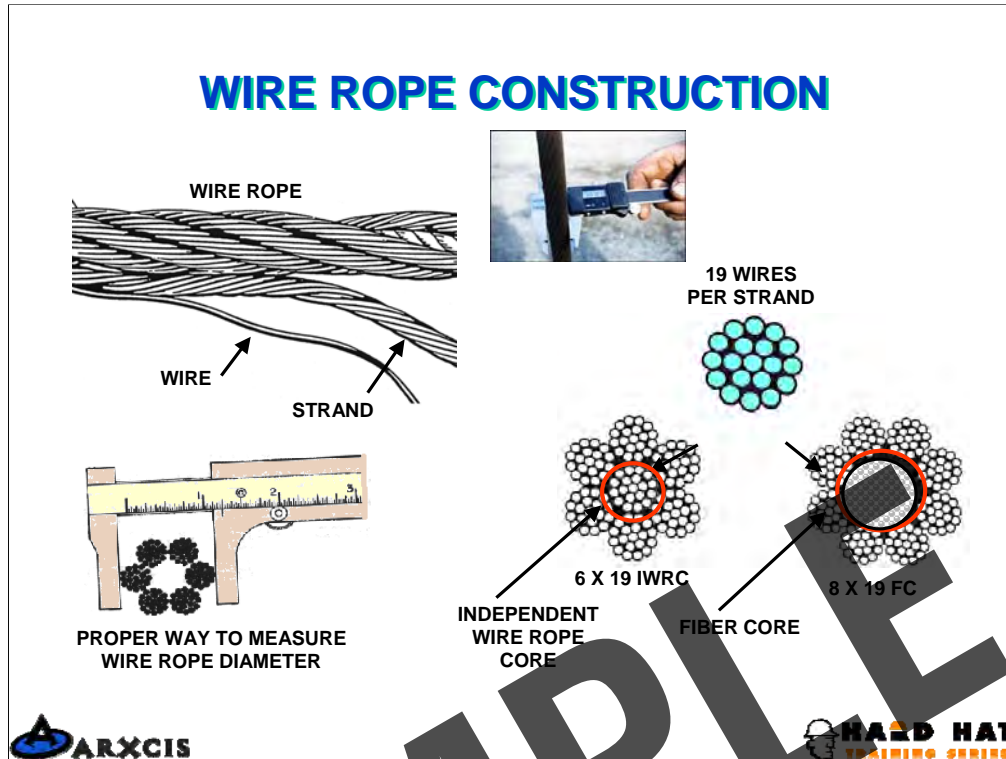

OBJECTIVE: To discuss the construction of wire rope.

1. Wire rope comes in various sizes and construction. The most common is the right regular lay wire rope of the 6X19 class.
2. The strands of a wire rope are made up of several wires twisted together.
3. Several strands are twisted together to form the wire rope.
4. Common wire rope will have either a fiber core or an independent wire rope core or IWRC. For lifting purposes, IWRC is recommended because it resists crushing.
5. The designation, 6X19, refers to the basic construction. The '6' stands for the number of strands, not counting the core, that are used in the rope. The '19' refers to the number of wires in each strand.
6. When measuring the diameter of wire rope, make sure to measure across the strands and not the flat area between the strands.

WIRE ROPE

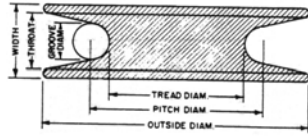

STANDARDS FOR SHEAVE & DRUM RATIOS

D = Diameter of drum or sheave
d = Diameter of wire rope
Ratio = D / d

ASNE/B30.5 "MOBILE CRANES" Minimum Ratios

	Drum	Sheave
Load Hoist	18	18
Boom Hoist	15	15
Load Block		16

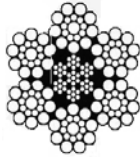

ABRASION RESISTANCE
Increases with larger wires
Decreases with smaller wires

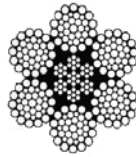

FATIGUE RESISTANCE
Decreases with fewer wires
Increases with more wires



OBJECTIVE: To discuss the basic considerations when selecting wire rope.

1. Point out the trade-offs between abrasion and fatigue resistance.
2. Show how sheave size and wire rope diameter relate to each other and the effects they have on wire rope life.
3. Review how sheaves are dimensioned.

ROTATION RESISTANT WIRE ROPE



The non-rotating characteristic is secured by building into the rope two layers of strands, one having Right Lay and the other Left Lay.

The tendency of one layer of strands to rotate in one direction is counteracted by the tendency of the other layer of strands to rotate in the opposite direction.



OBJECTIVE: To discuss rotation resistant rope and how it is constructed differently than other types of wire rope.

1. Point out how non-rotating rope is constructed. It has two layers of strands, one Right Lay and the other Left Lay.
2. These two layers rotate against one another, counteracting to keep the rope from rotating.

ROTATION RESISTANT WIRE ROPE

Rotation Resistant wire rope require very careful handling prior to, during and after installation. When a non-rotating rope is cut, bent around a thimble or wedge socket, or is attached to any fitting, care must be taken to prevent **core slippage**.

Core slippage can happen quite easily. When the rope is twisted in one direction, one layer of strands will tighten up and shorten, while the other layer of strands loosens, or becomes longer. As a result the shorter layers of strands carry the majority of the load.

To ensure that core slippage does not take place, always apply **wire seizings** to bind the inner and outer cores together before the rope is cut or attached to any fitting.

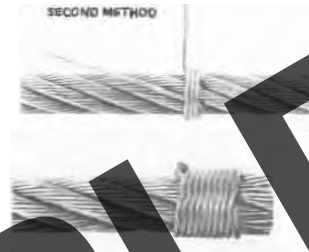
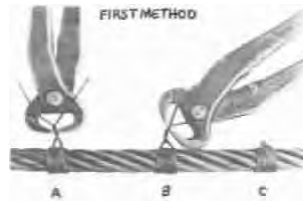

OBJECTIVE: To emphasize why Rotation Resistant wire rope must be handled differently than other types of wire rope.

1. Since Rotation Resistant rope is so different from other types of wire rope, the industry lists separate standards for its use.
2. Most Rotation Resistant rope's safety factor is at least 5:1. It is 10:1 when hoisting personnel.
3. ANSI has very strict procedures that must be followed when operating wire rope under a 5:1 safety factor
4. Rotation Resistant rope does not react well to bending around sheaves, thimbles or wedge sockets. Many manufacturers discourage the use of wedge sockets with non-rotating rope.
5. Great care must be taken when cutting non-rotating rope or attaching it to any fitting. To ensure that core slippage does not take place, the ends must have wire seizings applied prior to cutting or attaching it to any fitting.
6. Rotation Resistant wire rope should be inspected often.

WIRE ROPE INSPECTION

FATIGUE FAILURE



Heavy loads over small sheaves

STRAND KNICKING

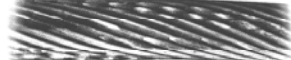

Accentuated with heavy loads

KINKED WIRE ROPE

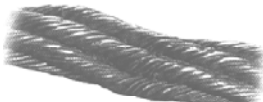

Crossed lines on drum

FATIGUE BREAKS



Repeated bending, normal loads

BIRDCAGE



Sudden tension release

HIGH STRAND

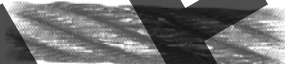

Improper socketing, kinks



OBJECTIVES: How to identify different types of wire rope problems.

1. Note the different types of damage and their causes.
2. Kinked rope is common on small cranes because of over running the wire rope when winching down.

AFTER THIS DISCUSSION HOLD A BRIEF REVIEW OF THE CRANE INSPECTION AND THEN ADJOURN TO THE CRANE FOR HANDS A HANDS ON EXERCISE. HAVE EACH PARTICIPANT CONDUCT AN INSPECTION.

BOOM TRUCK SETUP



SAMPLE

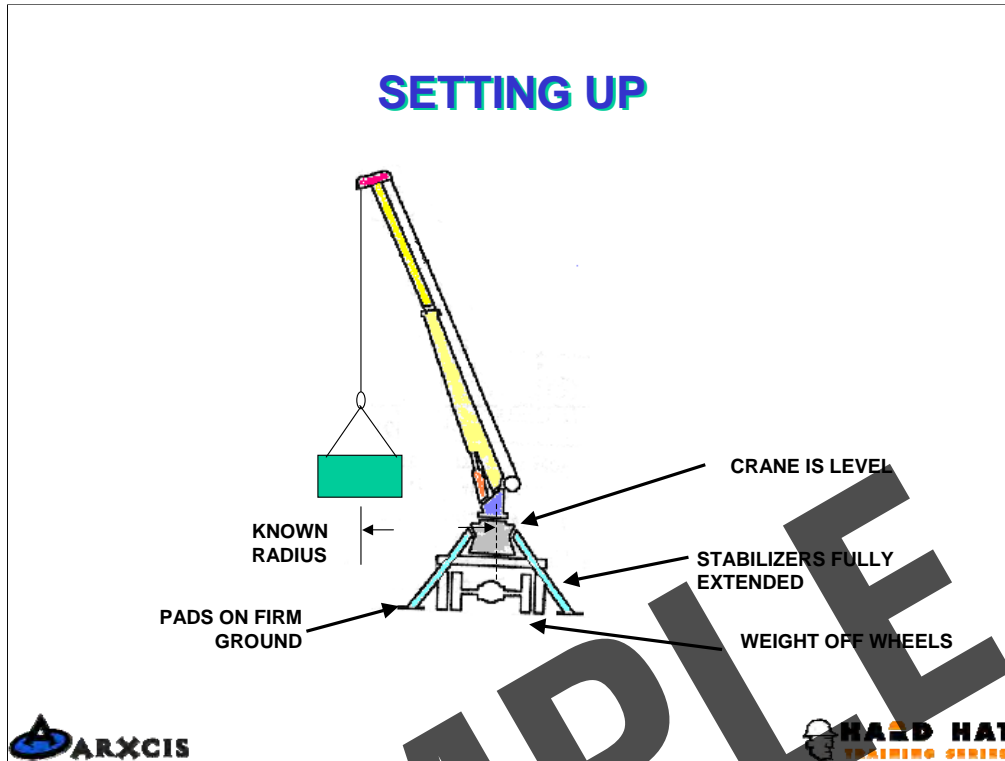

OBJECTIVE: This slide introduces the topic of boom truck set up.

1. Point out each of the areas that need to be taken into consideration when setting up the boom truck.
2. When the stabilizers are fully extended the tires may not be off the ground but the weight of the truck will primarily be on the stabilizers.

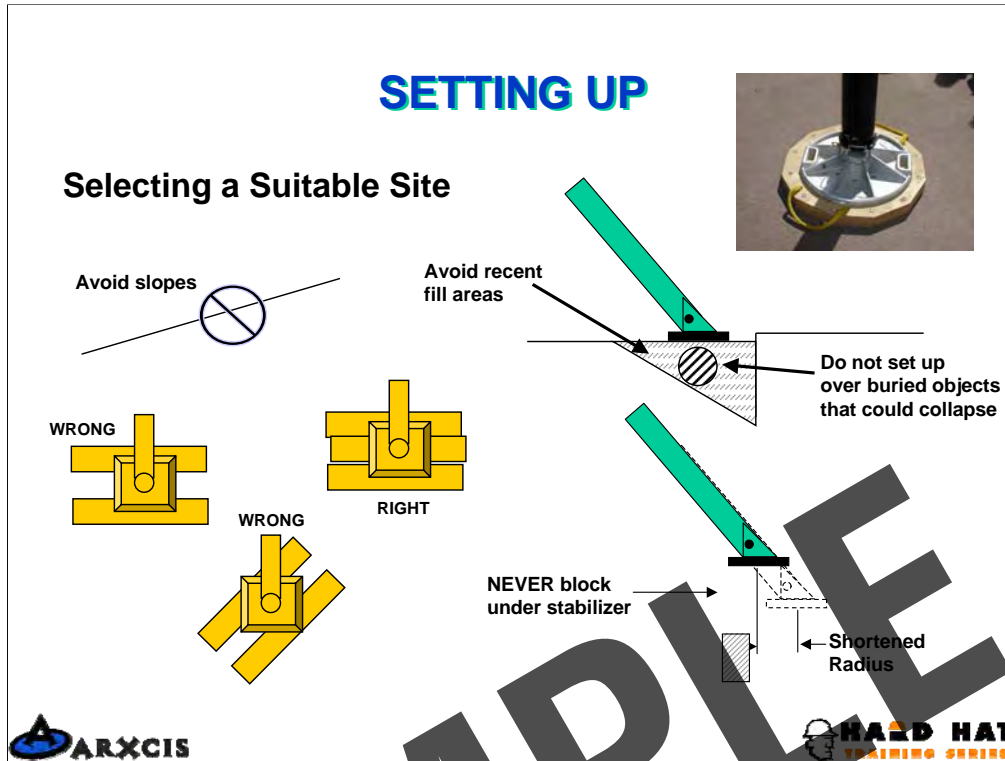

OBJECTIVE: To discuss the consideration that need to be understood to safely set the boom truck up.

1. The first consideration is the quality of the surface the boom truck will be set up on.
2. Soils along the foundation of buildings are often poorly compacted and may contain drain pipe and other voids. Setting up in these areas should be avoid when possible and additional floats used when not.
3. Floats of at least 24" X 24" should be used under each stabilizer pad regardless of the type of surface being set up on. The use of these floats will reduce the pounds per square inch loading on the surface which will help prevent the stabilizer from sinking.
4. Blocking under the A-frame type of stabilizer which prevents the stabilizer from fully deploying should be avoid. Doing so will shorten the distance from the stabilizer pad to the center of rotation which results in a lose of leverage for the boom truck and makes it more likely to tipping over.
5. Always extend both outriggers. Not doing so can result in the boom truck tipping over.

LEVELING THE CRANE

SWING BOOM
OVER REAR
& LEVEL CRANE
UNTIL HOIST
WIRE IS PLUMB
WITH BOOM

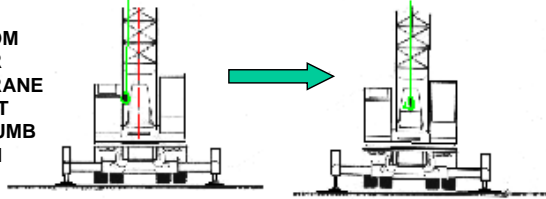

SWING BOOM
OVER SIDE
& LEVEL CRANE
UNTIL HOIST
WIRE IS PLUMB
WITH BOOM

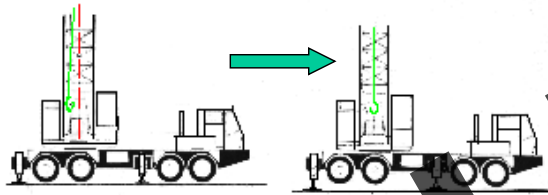

OBJECTIVE: To show how a crane can be leveled using the hoist line and the boom.

1. Leveling may take a few minutes but it is very important.
2. Boom trucks typically have a bubble level mounted at the control station which is used for leveling the crane.
3. In the absence of a bubble level, a carpenter's level can be placed on the turret for leveling purposes. The level will need to be positioned fore and aft and cross-wise to assure leveling in both directions.
4. A third way to level the boom is by using the hoist line as a plumb-bob. This is a very accurate leveling procedure. The above diagram illustrates the basic procedure.

ESTIMATED OUT OF LEVEL CAPACITY REDUCTIONS

BOOM LENGTH AND RADIUS	CAPACITY REDUCTION WHEN OUT OF LEVEL(Deg)		
	1	2	3
Short Boom, Minimum Radius	10%	20%	30%
Short Boom, Maximum Radius	8%	15%	20%
Long Boom, Minimum Radius	30%	41%	50%
Long Boom, Maximum Radius	5%	10%	15%



OBJECTIVE: The purpose of this slide is to illustrate how the boom truck being out-of- level can affect the its load capacity.

1. Review the chart with the students and emphasize how important it is to keep the boom truck level.
2. Note that the percentage of reduction is less when the boom is maximum radius than when the boom is at minimum radius. The following diagram will help to explain why.
3. Even though the change in boom angle, A & B are the same, the resulting change in the radius is much greater when the boom is raised high than when it is low. This is why the load capacity decreases more rapidly at high boom angles than at lower boom angles.

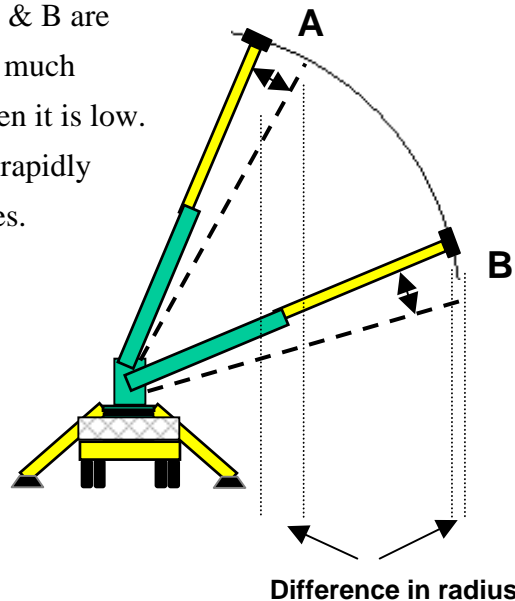

RADIUS AND BOOM ANGLE

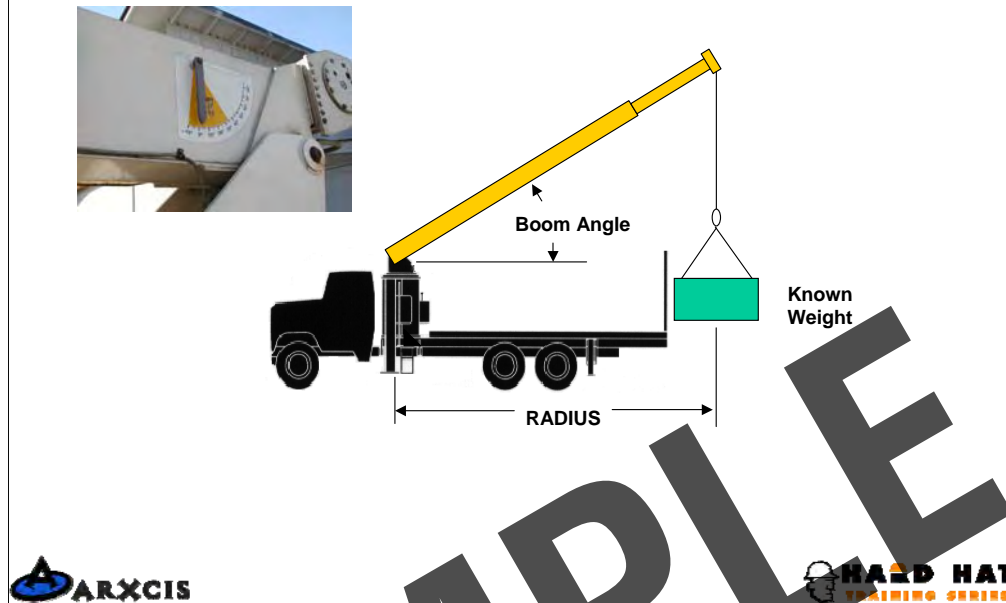

OBJECTIVE: The purpose of this slide is to point out the basic items which affect the boom truck's load capacity.

1. The radius for the load is measured from the center of rotation of the crane to directly under the vertically hanging hook.
2. The boom angle is measured from a horizontal line to the center of the boom.
3. The weight of the load and rigging must be known to determine the safe working load for a particular set-up configuration.

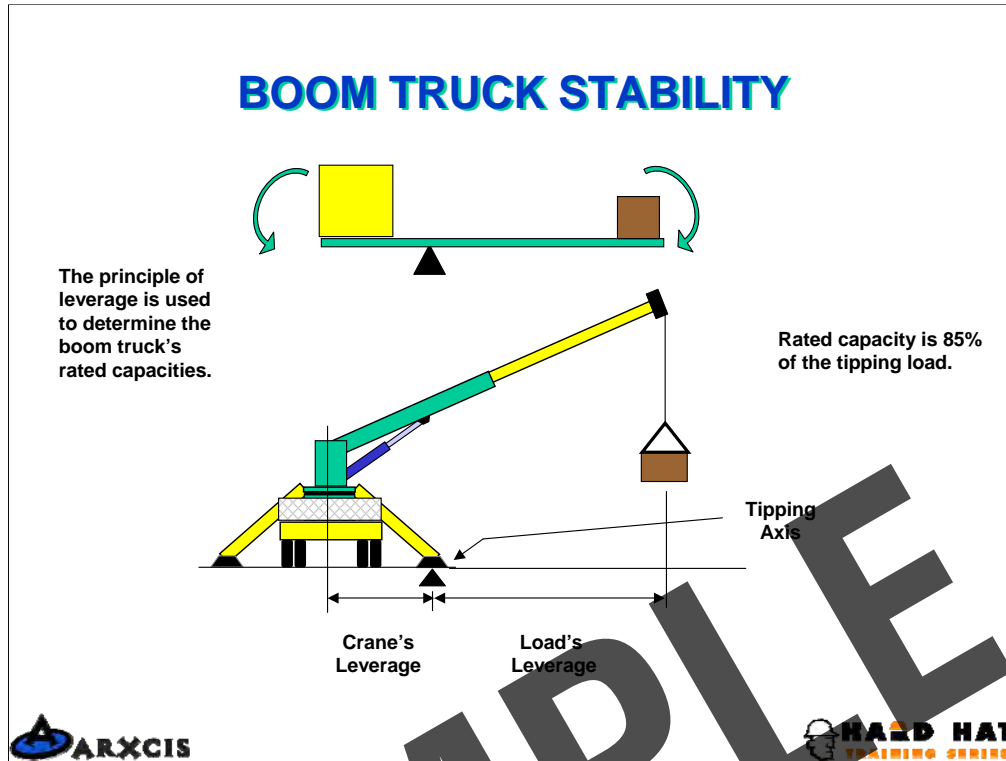

OBJECTIVE: To understand the dynamics of stability.

1. Boom truck stability is based on the concept of balance and leverage.
2. The concept of the teeter-totter is something that most people are familiar with and is a good way to explain stability.
3. When a teeter-totter is in perfect balance, the torque created by the weight times the length of the lever arm on one side of the pivot point must equal the torque created by the weight times the lever arm length on the other side.
4. For all cranes, the torque on the side of the crane always must be greater or otherwise the crane will tip over. The crane's torque or leverage is the effective weight of the crane times the distance from the center to the stabilizer. Leverage for the load is the weight of the load and that portion of the boom that is beyond the stabilizer pad times the distance from the stabilizer pad to the center of the load.
5. Note that the total weight of the load, boom, and a portion of the truck weight is on the stabilizer(s) over which the boom is working.

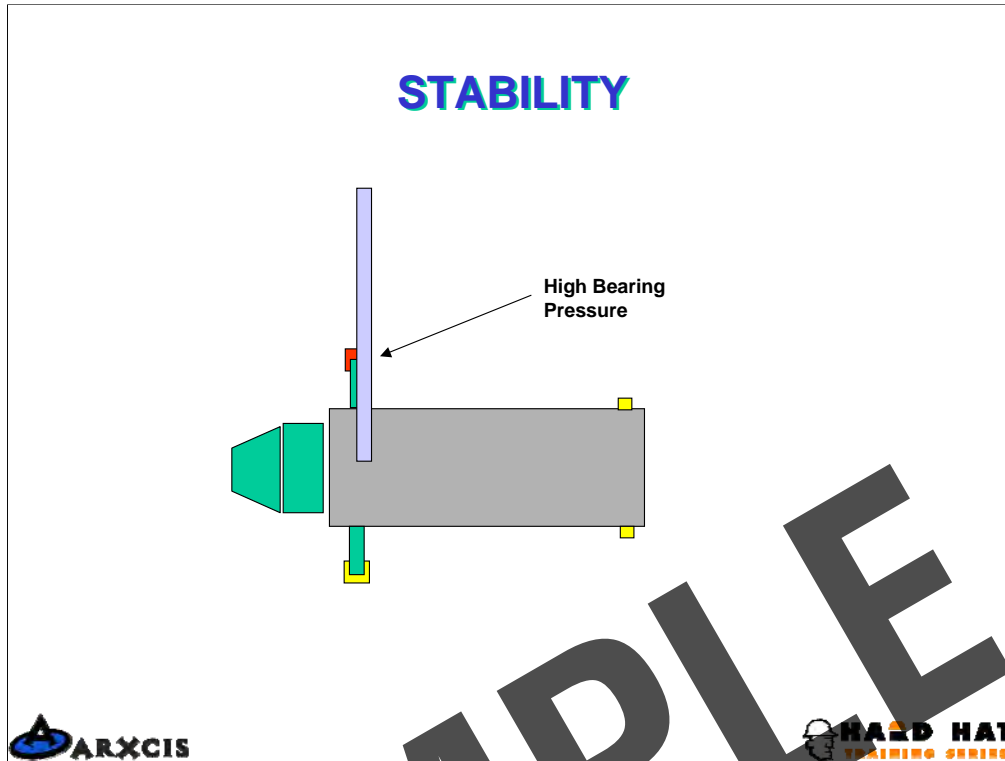

OBJECTIVE: To understand how the stability of the crane changes as the boom is rotated.

1. When the boom is located directly over the stabilizer, the pressure applied to the ground is the greatest because this one stabilizer is supporting most of the load.
2. Most boom truck pads are 12"X16" which equals 192 sq. in. of surface pressing on the ground. The load placed on this pad can be in the neighborhood of 20,000 lbs. This would result in a ground bearing pressure of 100 lbs per sq. in.
3. For this pressure the ground would need to be hard pan or compacted gravel soils. For many sites the soil conditions are poor and may be only able to support 40 lbs per sq. in.
4. A 24" X 24" float placed under the stabilizer pad will increase the surface area to 576 sq. in. This will yield a ground bearing pressure for the above situation of 34 lbs per sq. in. This is a much improved situation.
5. The students should be highly encouraged to have a set of floats for their boom truck and to use them for every set-up regardless of the soil conditions.

STABILITY

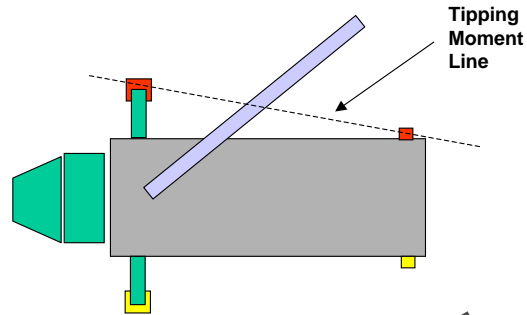

OBJECTIVE: To show how the load on the stabilizers change as the boom is rotated.

1. As the boom moves from over the forward stabilizer toward the back of the truck the pressure on the ground is shared by the two stabilizers.
2. The distance from the crane's center to the tipping moment line has increased so the leverage for the truck has increased making the boom truck more stable.
3. The students need to be cautioned about picking a load over the rear of the truck and swinging over the side. When initially picked, the boom truck may be very stable but as the load is swung over the side the boom trucks leverage decreases and making the truck less stable. Many operators are deceived by this condition and have resulted in a tip over.



**BOOM TRUCK
LIFTING
CONSIDERATIONS**



SAMPLE

LIFT REQUIREMENTS

- The Big Picture
- Assessing the Load
- Rigging Requirements
- Assessing the Pick Area
- Assessing the Placement Area



OBJECTIVE: To review the things the operator needs to consider before making a lift.

1. The Big Picture. The operator should take a moment to study the area in which he will be working. Look for power lines, obstructions, vehicle and pedestrian traffic, ground conditions and other potential areas to avoid in set-up.
2. When assessing the load the operator must know the weight. Along with this the load's center of gravity must be known in order to rig properly. Also the load's structural strength must be assessed to ensure that it will not be damaged during the lift.
3. What type of rigging will be required needs to be determined. The operator needs to ensure that the rigging is equal to the job.
4. Where the load will be picked from and where it needs to be placed must be determined. This is necessary so the boom truck can be placed so that both picking and placing of the load will remain within the load chart.

DETERMINING LIFTING CAPACITY

- Calculate the gross load
- Determine the maximum radius
- Determine the maximum height
- Refer to load chart to determine if lift will be within the boom truck's capacity.



OBJECTIVE: To review what things need to be considered for determining if the boom truck is capable of safely making a lift.

1. A discussion of determining what the gross load will be is on the next slide.
2. The operator may need to make a few measurements if the lifting requirements are close to the maximum capacity for a certain configuration. Guessing or even pacing off the radius may result in a tip over if wrong.
3. When placing loads at elevated heights, the operator must know these heights to determine if his boom truck is capable of making the pick.
4. A lengthy discussion on load charts is presented shortly.

GROSS LOAD

Gross Load =
▮ Net Load +
▮ Rigging +
▮ Wire Rope +
▮ Block +
▮ Boom Attachments

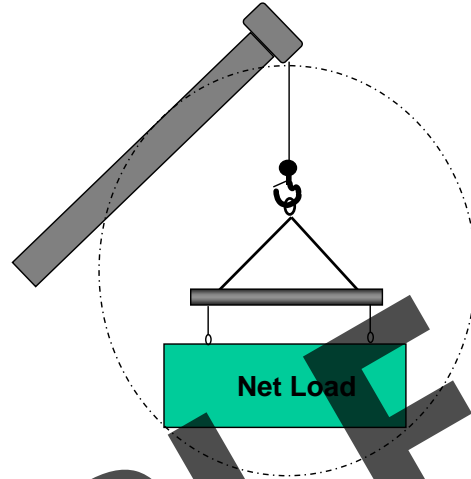

OBJECTIVE: To determine what constitutes the gross load.

1. All crane load charts are based on the load being anything that is hanging below the tip of the boom.
2. All of the above items listed on the slide technically need to be considered but for boom trucks, the weight of the hoist line can be neglected.

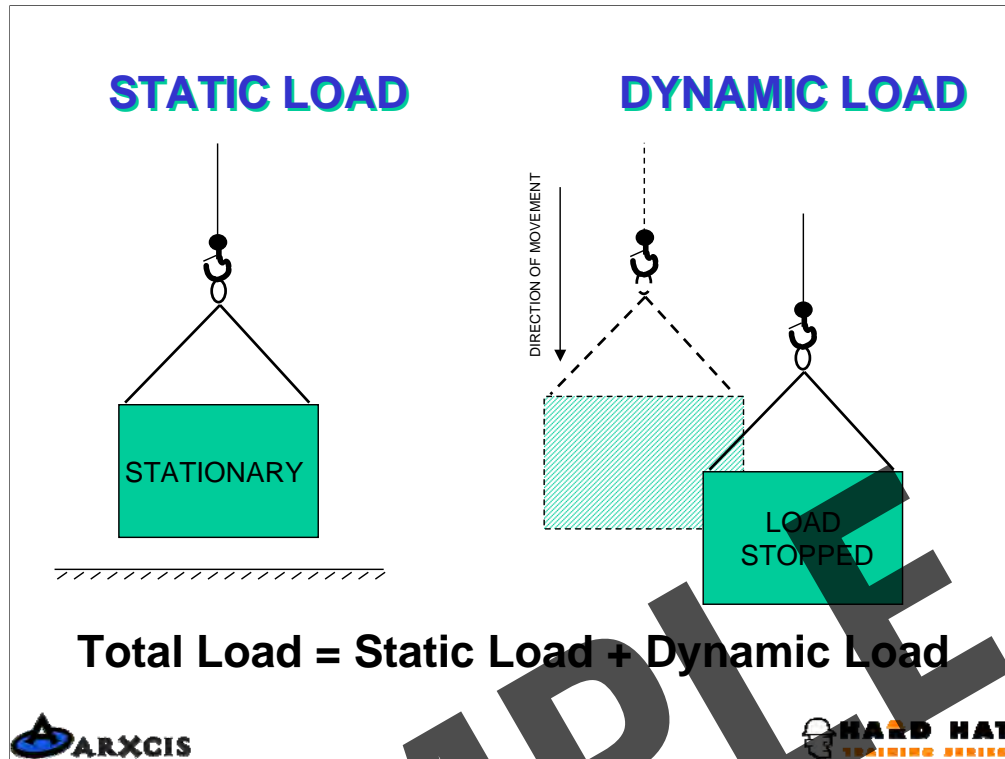

OBJECTIVES: To help the student understand how additional stresses can be imposed on the boom truck when the load is moved.

1. When a load is moved, additional stresses are imposed on the crane's structure.
2. Newton's first and second laws of motion basically state that a body at rest wants to remain at rest and a body in motion wants to remain in motion until acted upon by an outside force.
3. To start a load moving either by hoisting, booming or swinging, the crane will have to exert an additional force. How much additional force imposed is dependent on the weight of the load and how fast a load is started moving. Loads started slowly and stopped slowly will not exert as much stress on the crane as those which are moved rapidly.

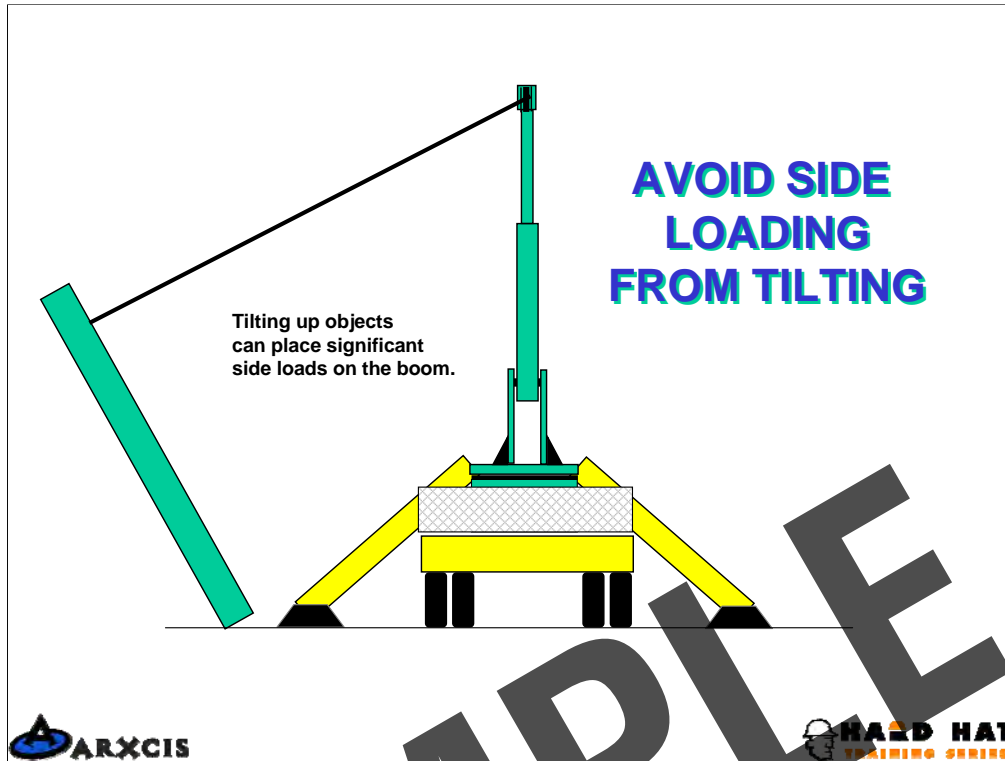

OBJECTIVE: To emphasize the negative impact that side loading can have on the boom.

1. The boom is very susceptible to side loading damage and needs to be above the load at all times.
2. Tilting up panels are a common cause of side loading. When tilting up a panel, the load line must remain vertical at all times.

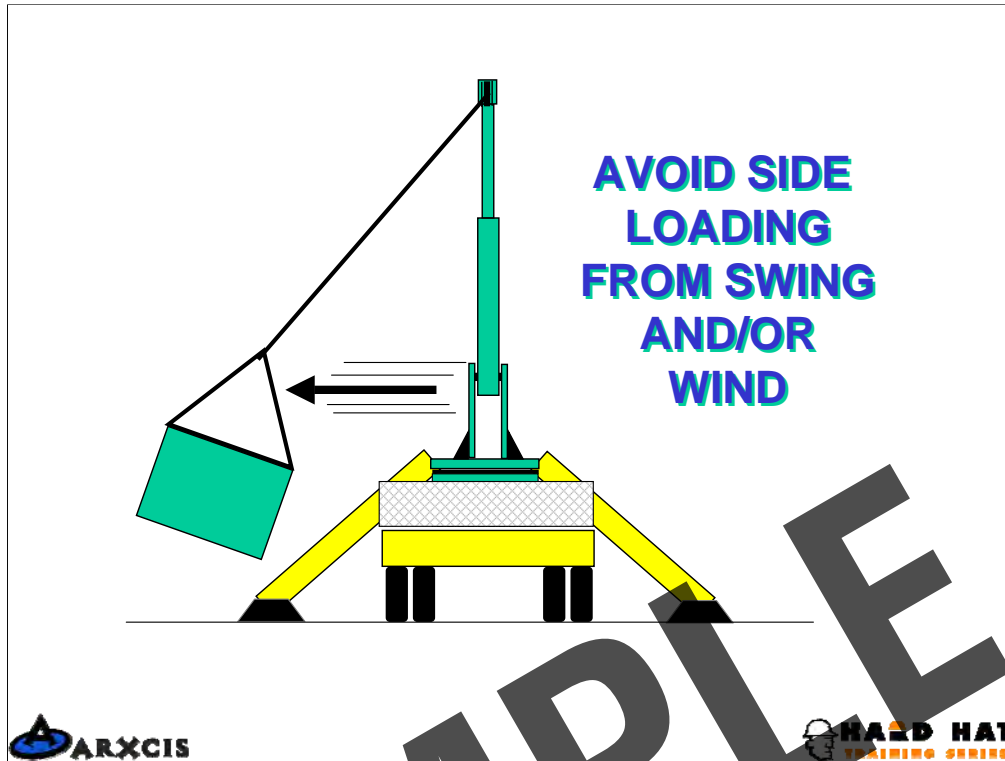

OBJECTIVE: To show how wind can have a negative affect on the crane.

1. Although it is not very apparent, wind can cause excessive stresses on the crane.
2. Wind on the boom itself, especially when extended fully, can contribute to a tip over. The operator must stop operations when the wind becomes a significant factor. When to stop is left to the judgement of the operator.
3. The wind pressure on the load can also add side loading to the boom as well as loosing control of the load. Tag lines may be necessary to help control the load but should never be used to pull the load around.

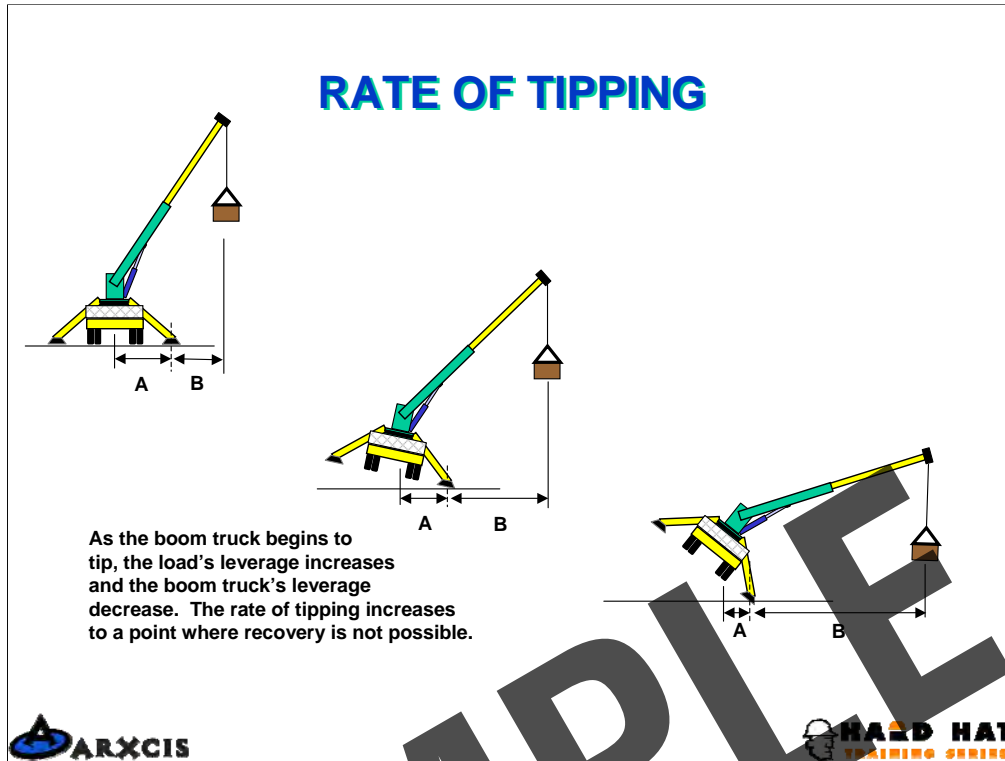

OBJECTIVE: To show how the rate or speed at which a boom truck tips increases the further it tips.

1. When in a stable situation, the boom truck leverage is greater than the load leverage.
2. As the boom truck begins to tip, the distance A becomes shorter and the distance B increases. This results in a decrease in leverage for the truck and an increase in leverage for the load.
3. As the boom truck continues to tip, distance A continues to decrease and distance B continues to increase. Tipping continues to increase at a faster rate.
4. Unless the operator is able to land the load immediately when the rate of tipping is slow, in a matter of seconds, it may be impossible to stop the tipping.

LOCATING THE CRANE

- Ground Stability
- Obstructions
- Power Lines
- Load Travel Path

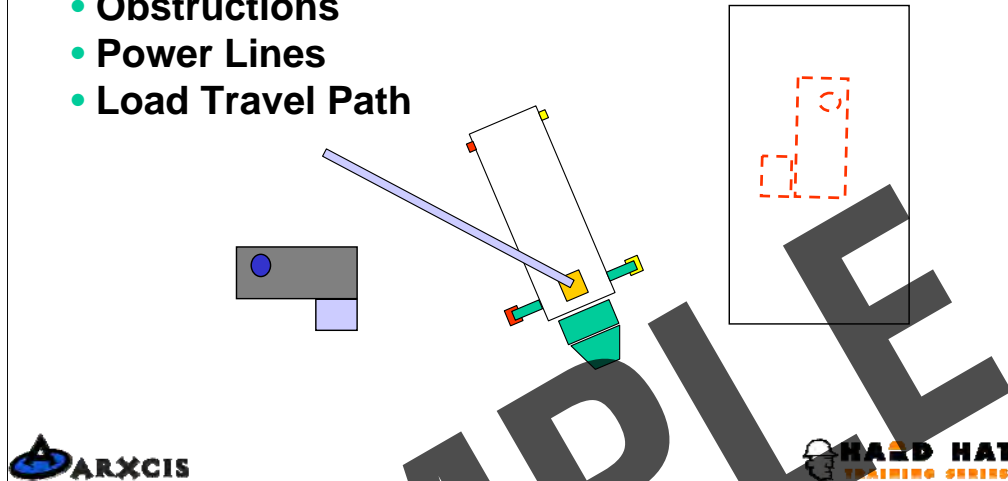

OBJECTIVE: This slide is to review the requirements for safely placing the boom truck.

1. Note all of the items listed above in determining the exact placement.
2. When the load exceeds 75% of the rated load capacity, the lift is considered a critical lift. Before the lift is attempted, a dry run should be performed to verify the boom truck is adequately located and the lift will remain within the parameters of the load chart.

BOOM TRUCK LOAD CHART



SAMPLE

LOAD CHART

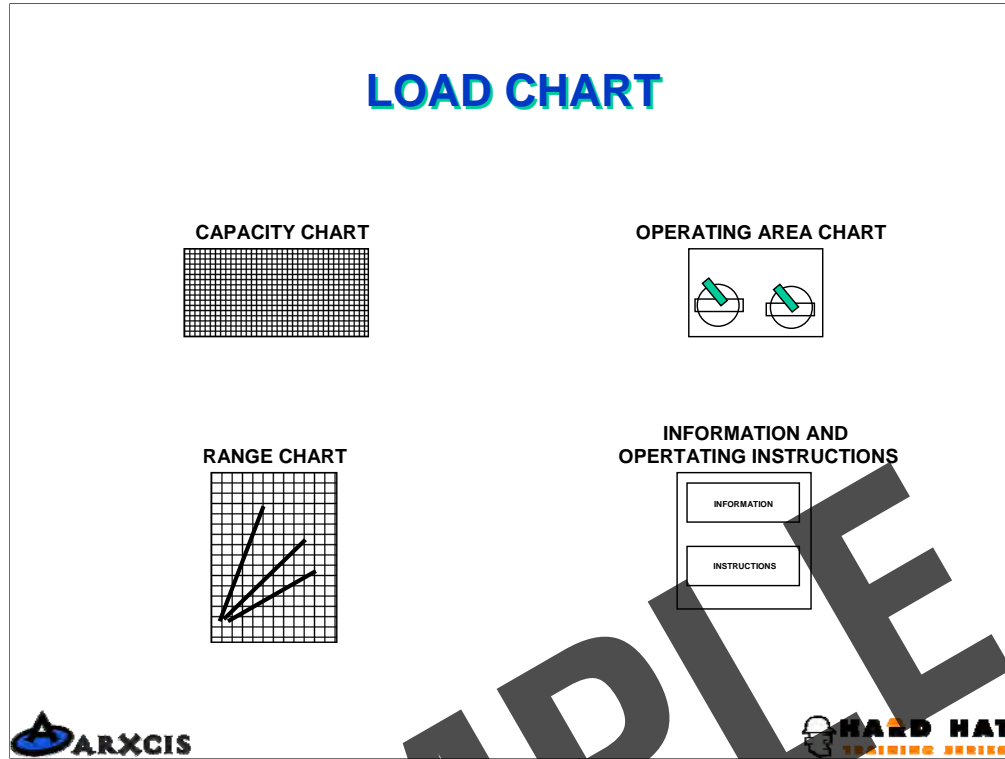

OBJECTIVE: This slide introduces the discussion on load charts.

1. Begin by indicating that most load chart will have at least 4 basic area of information
2. The operator is responsible for being familiar with and capable of using the load chart.

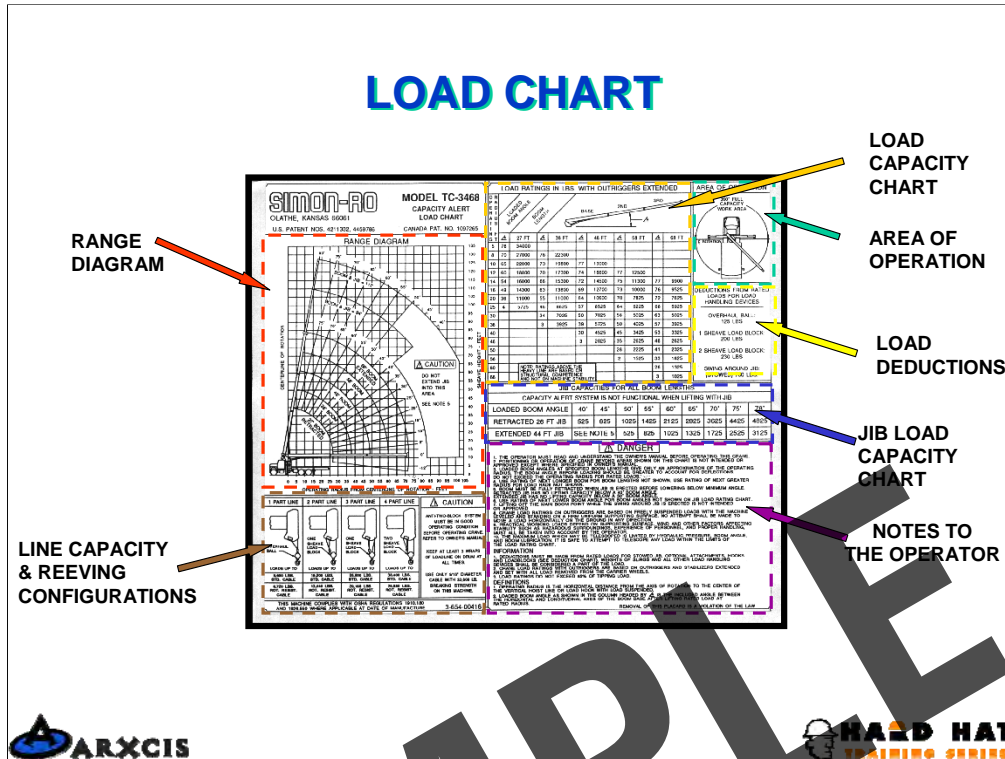

OBJECTIVE: To review each part of a typical load chart.

1. The load capacity section states the lifting capacity of the boom truck for a given radius and boom length.
2. The range diagram is used to plan lifts which will require a load to be picked or placed on top of an elevated structure.
3. The line capacity and reeving configurations section tells how much can be lifted for the different hoist line reeving configurations. Even though the load chart may indicate a certain lifting capacity, lifts need to be restricted to the capacity for the wire rope reeving configuration.
4. The operator is required to read and understand the information presented in the “notes to the operator” section.
5. If the crane is fitted with a jib, it will have a load chart showing the load capacity for various radii.
6. The section showing the various load deductions is very important to understand because these must be taken into consideration in determining how big of a net load the crane can safely lift.
7. Typically the load chart will have a section showing the area of operation or will make a statement concerning it in the notes section.

RANGE DIAGRAM

USED TO
DETERMINE
APPROXIMATE
DISTANCES
FOR PLANNING
PURPOSES

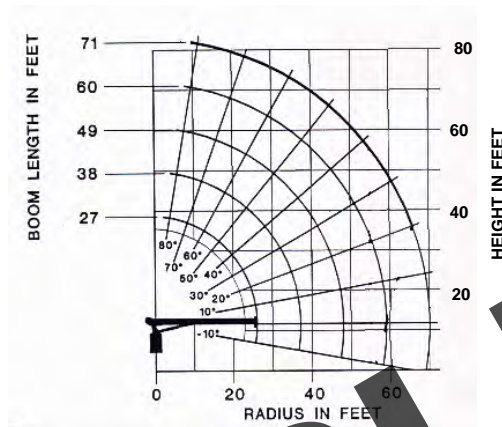

OBJECTIVE: To discuss the use of the range diagram.

1. The range diagram shows the various boom tip heights based on boom length and radius.
2. This diagram is useful in determining if a certain crane will have the lifting and range capacity to make a certain lift to or from the top of a structure.
3. Using the diagram in pre-planning can prevent the boom truck be sent to a job site and being inadequate for the job.
4. Note that there is an arc for each boom length section.

RATED LOAD CAPACITY CHART

LOAD RADIUS (FEET)	LOADED BOOM ANGLE	27FT BOOM (LBS)	LOADED BOOM ANGLE	38FT BOOM (LBS)	LOADED BOOM ANGLE	49FT BOOM (LBS)	LOADED BOOM ANGLE	60FT BOOM (LBS)	LOADED BOOM ANGLE	71FT BOOM (LBS)	RATED LOAD DEDUCTIONS
10	67	17,900	74.5	16,100	78.5	14,900					(LBS)
12	62.5	15,400	71.5	13,900	76	12,800	79	11,800			DOWNHAUL
14	57	13,700	68	12,200	73.5	11,200	77	10,400	79.5	10,000	WEIGHT = 150
16	52	12,300	64.5	10,900	71	9,900	75	9,200	77.5	8,800	
20	39.5	10,000	57	9,000	66	8,200	71.5	7,600	70.5	7,200	ONE SHEAVE
25	17	7,600	49	7,500	60	6,800	66.5	6,200	70.5	5,800	BLOCK = 200
30			37.5	6,300	53	5,700	61	5,200	66	4,900	
35			21	5,000	44.5	4,900	55	4,500	61.5	4,200	TWO SHEAVE
40					35	4,200	49	3,900	56.5	3,600	BLOCK = 355
45					22	3,500	42	3,300	51.5	3,150	
50							34	2,900	46	2,750	STOWED
55							23	2,500	40	2,400	JIB = 500
60									33	2,100	
65									23.5	1,750	
70									4	1,100	
	0	6,000	0	3,800	0	2,400	0	1,550	0	950	



OBJECTIVE: To review the load capacity chart.

1. A typical load capacity chart will show the radius in the left hand column.
2. Corresponding to each radius, subsequent columns to the right will show a corresponding boom angel and boom length.
3. If a desired radius falls between to radii shown on the load chart, the next longer radius must be selected and the associated capacities are used. For example: If the boom length is set at 38 feet and the measured radius was 27 feet, the maximum lifting capacity will be 6,300 lbs. which is associated with 30 foot radius. It is not permissible to 'split the difference' for a capacity at a radius of 27 feet.
4. The boom angles shown on the chart are for loaded booms. When setting up for a lift where the boom angle is to be used as the mean of establishing the radius, 2 degrees should be added to the load chart number. As the boom is loaded it will tend to droop somewhat and the added 2 degrees will compensate for that.

RANGE DIAGRAM EXERCISE

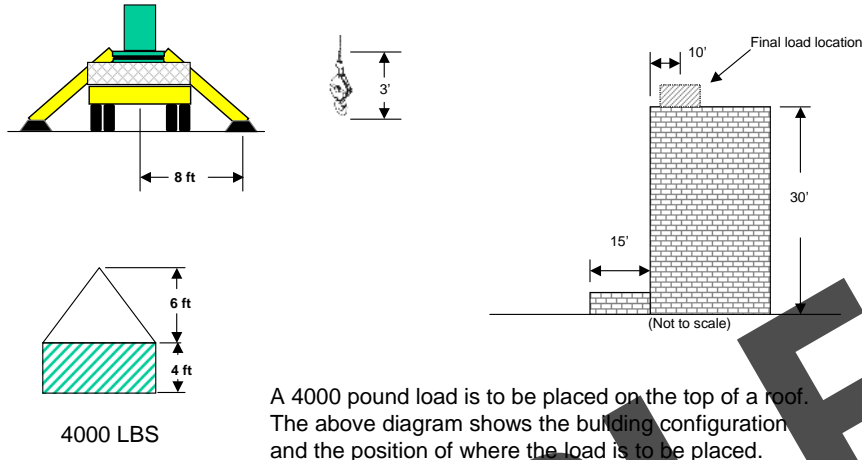

OBJECTIVE: To demonstrate how to use the range diagram and load chart for planning a lift.

1. Explain the problem to the students and walk them through each part.
2. A separate range diagram will be helpful for them to sketch the problem.
3. The overall load height is 10ft. This is the height of the load and the rigging combined.
4. The typical distance from the center of rotation to the stabilizer pad is 8 feet. The actual distance can be found in the operators manual.
5. For this problem it is assumed that the stabilizer pad can be placed against the base of the 15 foot porch.

RANGE DIAGRAM EXERCISE

Step One: Calculate the total gross load including deductions

Load	= 4000 lbs
Load Deductions	= 700lbs (1 sheave block, 200 lbs; stowed jib, 500 lbs; rigging and load line negligible)
Total gross load	=4700 lbs

Step Two: Minimum boom tip height for this lift.

Building height	= 30 ft
Load & rigging height	= 10 ft
Hook height	= 3 ft
Minimum free line	= 5 ft

Minimum boom tip height	= 48 ft
-------------------------	---------

Step Three: Minimum radius for this lift.

Center of rotation to stabilizer	= 8 ft
Stabilizer to edge of building	= 15 ft
Edge of building to load center	= 10 ft

Minimum radius	= 33 ft
----------------	---------



OBJECTIVE: To show how the calculations are done.

1. First, calculate the total load to be imposed on the crane. Remember to include any load deductions along with the net load.
2. The next step is to determine the minimum boom height required to make the lift safely. In this example the building is 30 feet tall. The load with rigging will require another 10 feet. The hook and associated hardware is 3 feet and we have determined that we want at least 5 feet for free operating room. If the crane has an anti-two block device installed, an additional length will be required.
3. The third step is to determine the minimum radius at which the crane can make the lift. The closest the boom truck can get to the building is 8 feet, the distance from the center of rotation to the stabilizer pad. Next is the 15 foot wide porch and added to that is the 10 feet from the edge of the building to the center of the load.

RANGE DIAGRAM EXERCISE

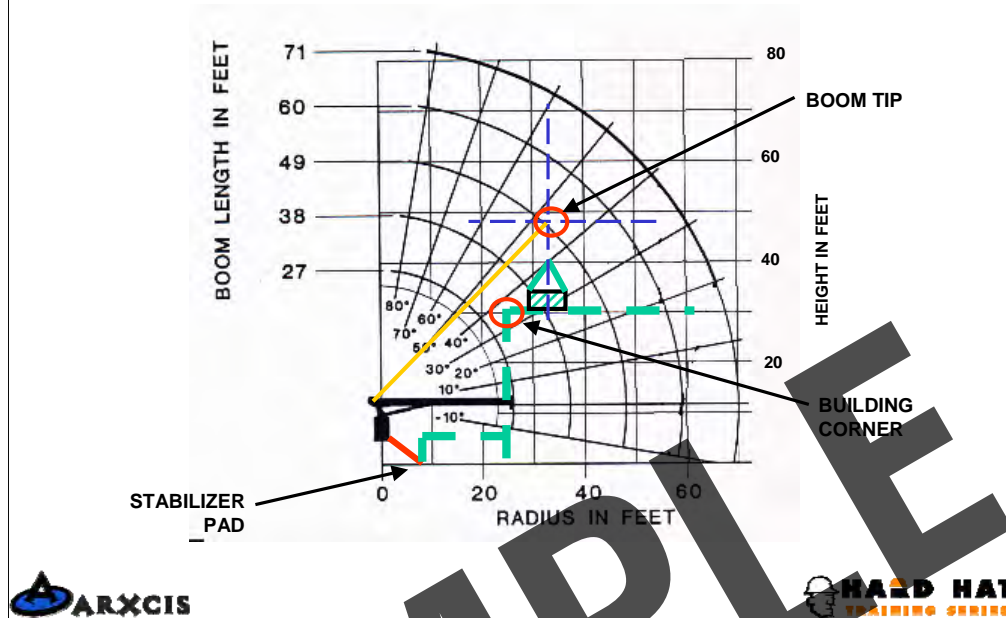

OBJECTIVE: To show how to place the data on the range diagram and determine if the lift can be made.

1. First we can draw a horizontal line at 30 feet high, the height of the building.
2. Next we draw a vertical line at 23 feet of radius which represent the side of the building. The intersection of these two lines is the corner of the building.
3. At 33 feet of radius, draw a vertical line from the top of the building upward. This represents the center of the load and where the hoist line will need to be in order to place the load on top of the building.
4. At 48 feet of height from the ground, draw a horizontal (the minimum boom tip height) that intersects the vertical line representing the hoist line. The intersection of these two lines is lowest point the boom tip can be placed and still make the lift.
5. A line drawn from the boom hinge to boom tip point will show the minimum boom angle and will also show how much clearance the boom has from the edge of the building.
6. The next thing to be determined is the length of boom required. This is determined from the boom length arcs. In this case the 49 foot boom length will barely meet our requirements. Checking the load chart on the next slide for 49 foot boom and 35 foot radius shows a lifting capacity of 4,900 lbs. The total gross load is 4,700 lbs and therefore the lift can be made but it will be considered a critical lift which will require that all of the conditions be checked and verified.

RANGE DIAGRAM EXERCISE

Step 4: Sketch the building and load placement on the range diagram.

Step 5: Draw a vertical line through the load center, intersecting the boom tip arcs. Identify the shortest boom length which provides the minimum boom tip height and provides sufficient clearance from the boom to the building.

Step 6: Knowing the boom length and the minimum radius, locate on the load capacity chart the load capacity for this particular set-up.

LOAD RADIUS (FEET)	LOADED BOOM ANGLE	27FT BOOM (LBS)	LOADED BOOM ANGLE	38FT BOOM (LBS)	LOADED BOOM ANGLE	49FT BOOM (LBS)	LOADED BOOM ANGLE	60FT BOOM (LBS)	LOADED BOOM ANGLE	71FT BOOM (LBS)	RATED LOAD DEDUCTIONS (LBS)
10	57	17,900	74.5	16,100	78.5	14,900					(LBS)
12	52.5	15,400	71.5	13,900	76	12,800	79	11,800			DOWNHALL
14	57	13,700	68	12,200	73.5	11,200	77	10,400	79.5	10,000	WEIGHT = 150
16	52	12,300	64.5	10,900	71	9,900	75	9,200	77.5	8,800	
20	38.5	10,000	57	8,000	66	6,200	71.5	7,600	70.5	7,200	ONE SHEAVE
25	17	7,800	49	7,500	60	6,800	66.5	6,200	70.5	5,800	BLOCK = 200
30			37.5	6,300	53	5,700	61	5,200	66	4,900	
35			21	5,000	44.5	4,800	55	4,500	61.5	4,200	TWO SHEAVE
40					35	4,200	49	3,900	56.5	3,600	BLOCK = 355
45					22	3,500	42	3,300	51.5	3,150	
50							34	2,900	46	2,800	STOWED
55							23	2,500	40	2,400	JIM = 500
60									33	2,100	
65									23.5	1,750	
70	0	6,000	0	3,800	0	2,400	0	1,250	0	550	



OBJECTIVE: Continuation of the previous slide.

SAMPLE



**BOOM TRUCK
SAFETY**



SAMPLE

CRANE SAFETY

- ☒ Avoid two-blocking the crane, use an anti-two blocking device
- ☒ Do not leave the crane with a suspended load
- ☒ Rig the crane with sufficient parts of line for the load
- ☒ Always have a minimum of three wraps of cable on the drum
- ☒ Monitor the winch to make sure that it is spooling correctly
- ☒ Do not lift loads over personnel
- ☒ Lift one load at a time
- ☒ Maintain correct electrical clearance
- ☒ Never use the hoist line as a sling



OBJECTIVE: To review the points for a safe lift.

MAKING THE LIFT

- ▣ Review the lift scenario with the operator, riggers and signal person
- ▣ Attach taglines when necessary
- ▣ Position signal person within visibility of the load and operator
- ▣ Begin by lifting the load slowly
- ▣ Re-check the boom angle indicator to assess radius increase
- ▣ Keep load as low as possible when moving it
- ▣ Swing slowly to avoid swing out.
- ▣ Avoid erratic booming
- ▣ Follow signal and stop operation when uncertain
- ▣ Lower load slowly



OBJECTIVE: To review the conditions for making a safe lift.

SAMPLE

HAND SIGNALS



DOG EVERYTHING



EXTEND BOOM



EMERGENCY STOP



**LOWER THE LOAD
RAISE THE BOOM**



RETRACT BOOM



**RAISE THE LOAD
LOWER THE BOOM**



OBJECTIVE: To review the standard hand signals used in crane operations.

1. Emphasize the importance of using the standard hand signals to avoid misunderstandings which could lead to an accident.
2. When working at night, an orange glove is useful for good visible hand signals.

HAND SIGNALS



RAISE THE LOAD



RAISE THE BOOM



SWING



LOWER THE LOAD



LOWER THE BOOM



STOP



Continuation of previous slide.

SAMPLE

POWERLINE CONTACT

Required Clearances

50kV	10 ft
50 to 200kV	15 ft
200 to 350kV	20 ft

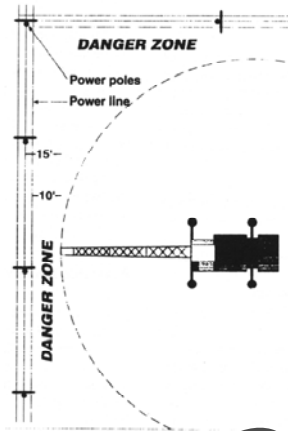

OBJECTIVE: To review the requirements for operating around power lines.

1. The minimum clearance requirements need to be observed.
2. It may be necessary to have an assigned spotter to watch the crane boom to ensure that it does not enter the danger zone.
3. Electrocution is the number one cause of death involving cranes.

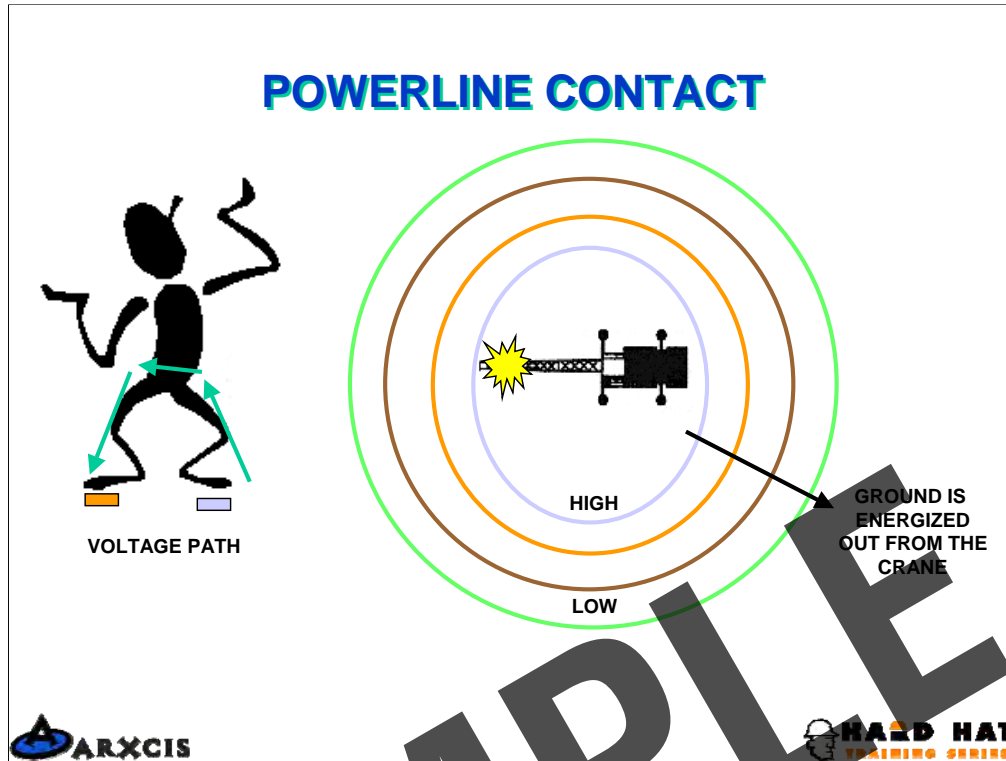

OBJECTIVE: To discuss what should be done in case of a power line contact.

1. The operator should remain with the crane if at all possible until the power company indicates it is safe to leave the crane. This is because the crane components could be at different voltage potentials and touching parts of the crane could result in being electrocuted.
2. No one should be allowed to approach the crane or to touch it. If the operator is unconscious, no attempt should be made to rescue him until the power company indicates it is safe to do so.
3. If the operator must leave the boom truck due to fire, he should shuffle to the edge of the platform he is standing on and carefully jump to the ground. It is important that he is able to land standing. Once on the ground, shuffle away from the boom truck.



**BASIC RIGGING
INSPECTION**



SAMPLE

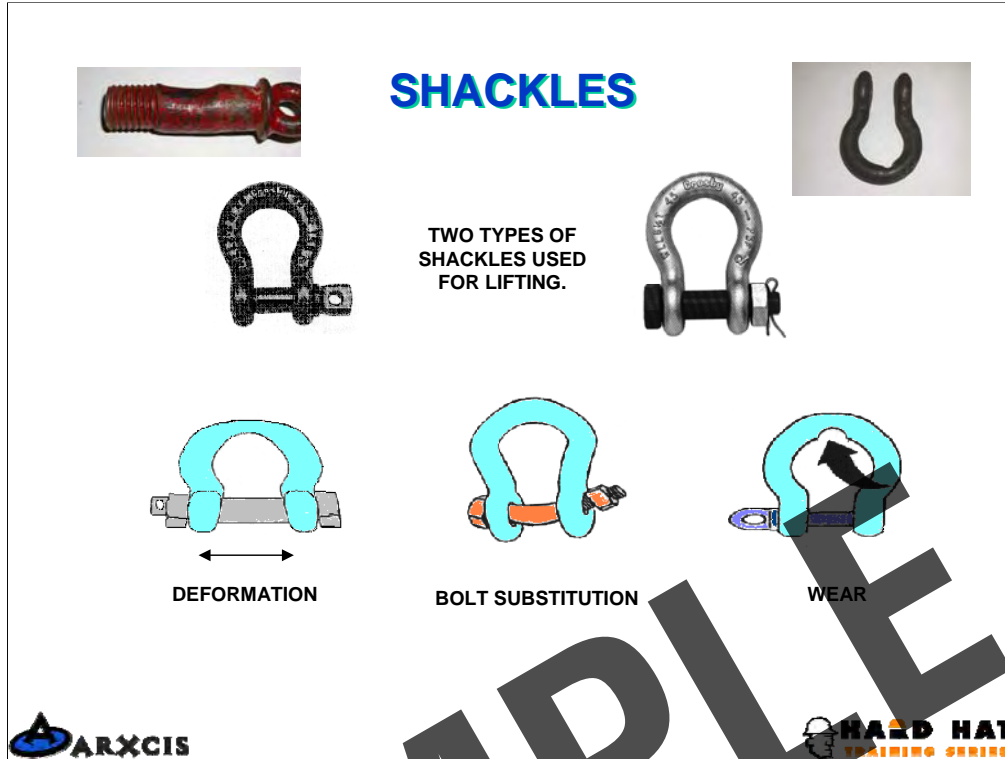

OBJECTIVE: To discuss the inspection and use of shackles.

1. Only two type of shackles are to be used in rigging for lifts. The screw pin type and the bolt type shackle.
2. Shackles that are damaged or deformed must be removed from service.

SHACKLES

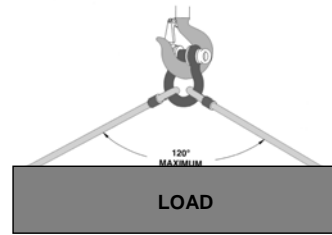
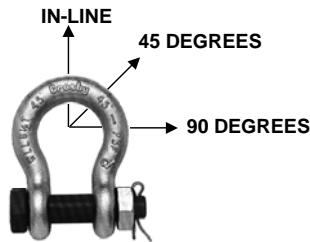

Side Loading Reduction Chart For Screw Pin & Bolt Type Shackles Only†	
Angle of Side Load	Adjusted Working Load Limit
0° In-Line	100% of Rated Working Load Limit
45° from In-Line	70% of Rated Working Load Limit
90° from In-Line	50% of Rated Working Load Limit

† DO NOT SIDE LOAD ROUND PIN SHACKLES



OBJECTIVE: To show how the load rating of the shackle changes.

1. The working load limit, WWL, shown on the shackle is for vertical loads.
2. Round pin shackles are ones which do not have a nut on the end of the pin and should not be used for lifting..

EYE BOLTS

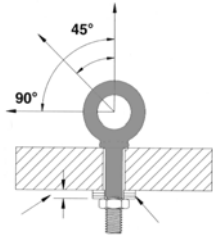

DIRECTION OF PULL	ADJUSTED WORKING LOAD
In-Line	Full Rated Working Load
45 Degrees	30% of Rated Working Load
60 Degrees	60% of Rated Working Load

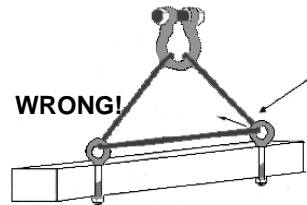

DO NOT REEVE SLINGS ONE EYE BOLT TO ANOTHER. LOAD ON BOLT IS ALTERED.

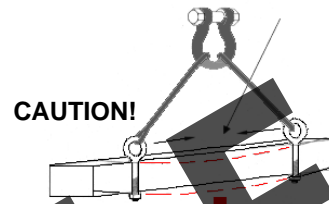

STRUCTURE MAY BUCKLE FROM COMPRESSION FORCES.



OBJECTIVE: To show how the load capacity of the eye dramatically change when loaded other than vertically.

1. The rated capacity of a eye bolt drops significantly when pulled other than vertically.
2. Emphasize the dramatic drop to the students.
3. Threading a sling through the eye bolts increases the stress on the eye bolts by two and should never be done.

WIRE ROPE SLING INSPECTION

KINKING
CRUSHING
UNSTRANDING
BIRDCAGING
STRAND DISPLACEMENT
CORE PROTRUSION
CORROSION
BROKEN OR CUT
STRANDS
BROKEN WIRES

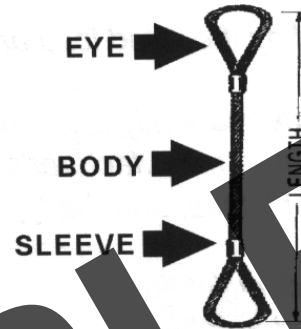

OBJECTIVE: To review the requirements for inspecting wire rope slings.

1. Wire rope slings are to be inspected on a regular basis and a record kept of these inspections. Refer to the inspection card for inspection criteria.
2. As of July 2000 wire rope slings are to have a tag which indicates the lifting capacities of the sling for vertical, choker, and basket hitches.

CHAIN SLING INSPECTION

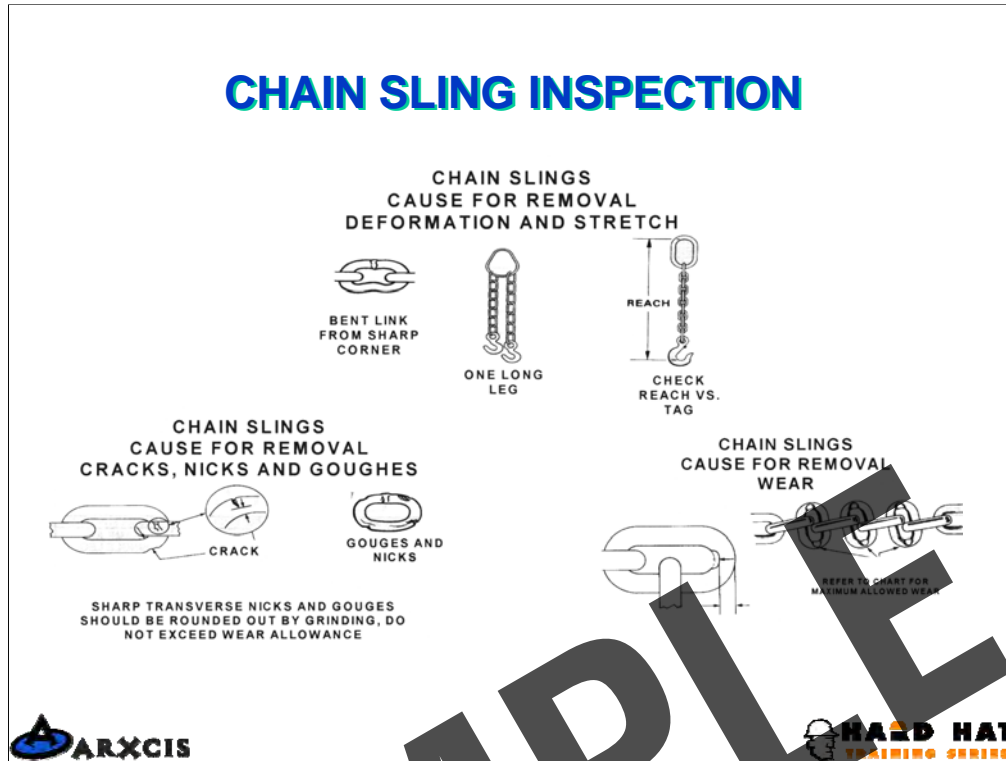

OBJECTIVE: To review the requirements for inspecting chain slings.

1. Chain slings are to be inspected on a regular basis and a record kept of these inspections. Refer to the inspection card for inspection criteria.
2. Chain slings are often used to hold steel while it is being welded. Always check to make sure no heat damage has occurred. Heat damage can be detected by discolored metal.

SYNTHETIC SLING INSPECTION

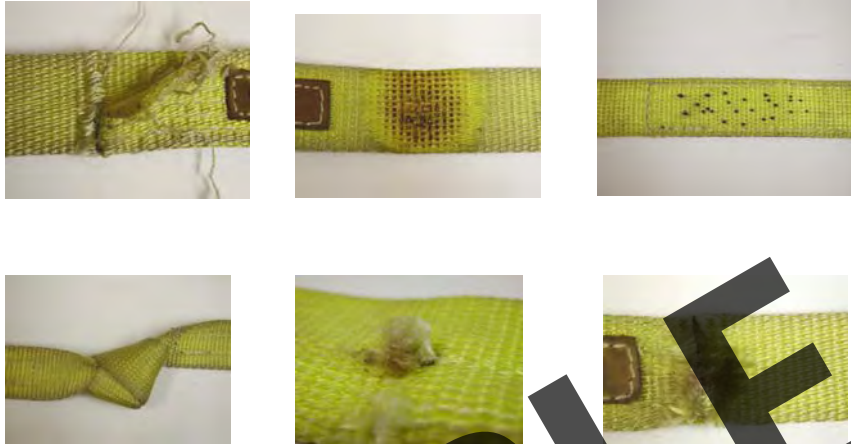

OBJECTIVE: To review the requirements for inspecting synthetic slings.

1. This slide and the next two show the different types of sling damage that can occur. Refer to the inspection record of additional inspection criteria.
2. Synthetic slings are required to be inspected on a regular basis and a record kept of such inspections.

SYNTHETIC SLING INSPECTION

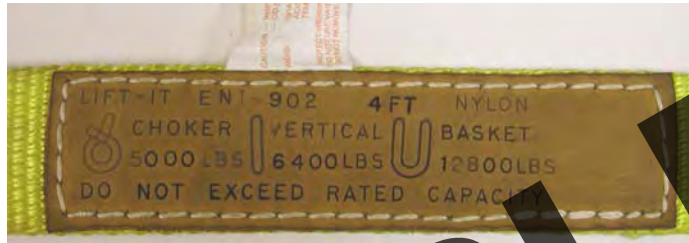

COMPLIMENTS
OF LIFT-IT



Continuation of previous slide.

SAMPLE

SLING ANGLES

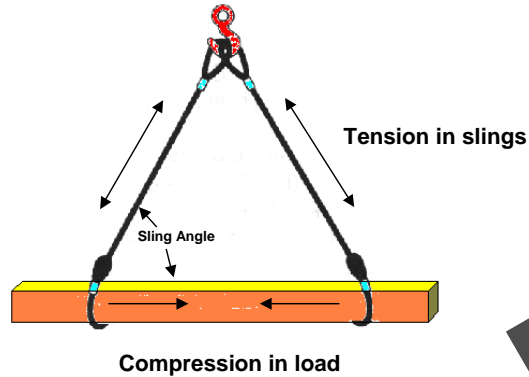

Stresses in the slings and the load increase as the sling angle decreases



OBJECTIVE: To review the basics of sling loading.

1. When slings are brought together and form a hitch arrange as shown above the stresses in the slings increase and a compression force on the load is created.
2. As the sling angle decrease the stresses in the sling and on the load increase.

SLING ANGLES

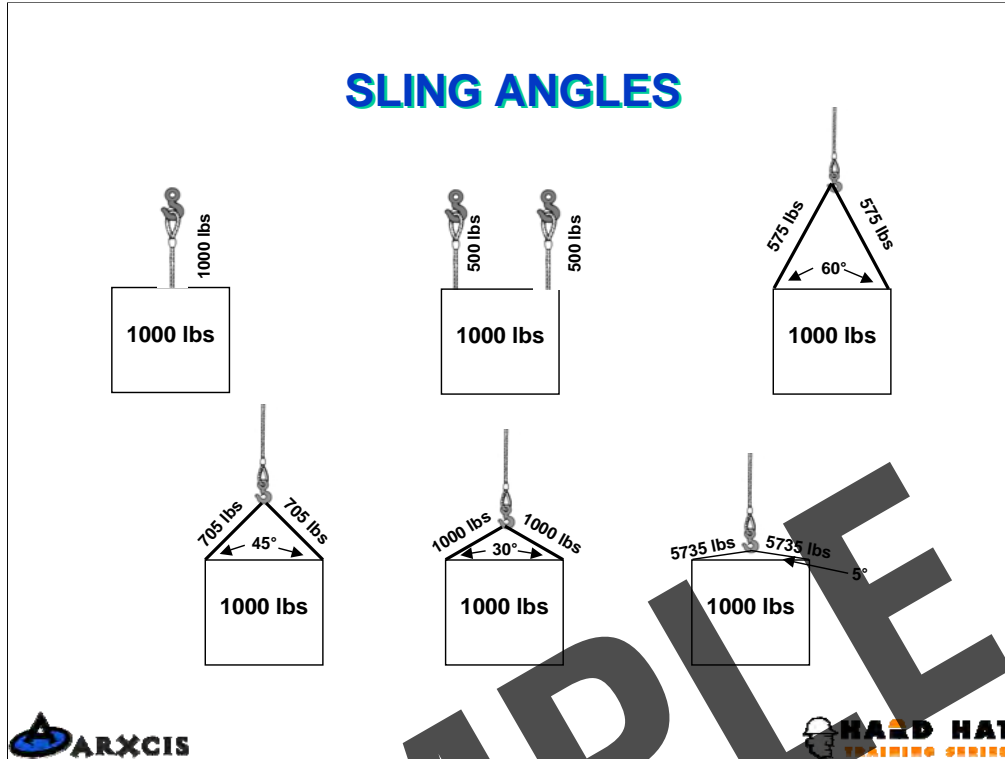

OBJECTIVE: To show how the stress in the slings increase as the sling angle decreases.

1. Review each of the different sling angle configurations and point out the increase in the stresses.
2. Sling angles of 60 degrees are the best to use because of the minimal increase of stress in the slings. When required to use smaller sling angles, slings need to be selected based on the increased stress and not on the weight of the load.
3. When the sling angle is 30 degrees for a 1000 lbs load, the compression loads which are crushing the load will be 866 lbs. Depending on the structural strength of the load, it may be damaged.

SLING ANGLES

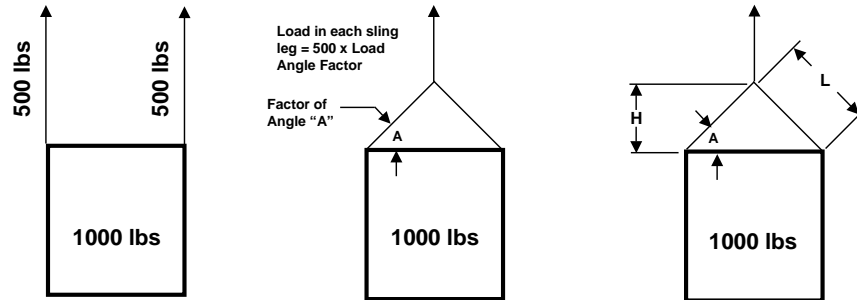

Sling Angle Degree (A)	Load Angle Factor = L/H
90	1.000
60	1.155
50	1.305
45	1.414
30	2.000

Load On Each Leg Of Sling = (Load / 2) X Load Angle Factor



OBJECTIVE: To show how the stresses in the slings can be determined.

1. All that is need to calculate these stress is the weight of the object and a measuring tape.
2. As shown in the slide above, the length of the sling is divided by the height of the sling connection to the top of the load.
3. The answer is then multiplied by the portion of the load it is to support and this will be the stress in the sling.

Example: If my sling was 8 feet long and the height 'H' was 4 feet, 8 divided by 4 equals 2. The portion of the weight the sling is to support is half of 1000 lbs or 500 lbs. $2 \times 500 = 1000$ lbs which is the stress in the sling.

ESTIMATING WEIGHTS

Acceptable methods of determining weight

You may find the weight from:

- Data on manufacturing label plates.
- Manufacturer documentation.
- Blueprints or drawings.
- Shipping receipts.
- Weigh the item.
- Bill of lading (be careful)
- Stamped or written on the load
- Approved calculations

Never use word of mouth to establish the weight of an item!



OBJECTIVE: To show the different means of determining the weight of a load.

SAMPLE

ESTIMATING WEIGHTS

Calculating the weight

To find the weight of any item you need to know its volume and unit weight.

- Volume x Unit weight = Load weight
- Unit weight is the density of the material
- Unit weight is normally measured by pounds per cubic foot.



OBJECTIVE: To emphasize the importance of knowing how to calculate weights.

SAMPLE

ESTIMATING WEIGHTS

Here are some examples of common materials and their unit weight:

METALS		TIMBER	
Aluminum	165	Cedar	34
Brass	535	Cherry	36
Bronze	500	Fir, seasoned	34
Copper	560	Fir, wet	50
Iron	480	Hemlock	30
Lead	710	Maple	53
Steel	490	Oak	62
Tin	460	Pine	30
		Poplar	30
MASONARY		Spruce	28
Ashlar masonry	160	White pine	25
Brick, soft	110	Railroad ties	50
Brick, pressed	140	LIQUIDS	
Clay tile	60	Diesel	52
Rubble masonry	155	Gasoline	45
Concrete, cinder, haydite	110	Water	64
Concrete, slag	130	EARTH	
Concrete, stone	144	Earth, wet	100
Concrete, reinforced	150	Earth, dry	75
MISC.		Sand and gravel, wet	120
Asphalt	80	Sand and gravel, dry	105
Glass	160		



OBJECTIVE: To show the unit weights for some common materials.

1. It's wise to have similar "cheat sheets" for materials that you handle frequently.

CALCULATING VOLUME

Volume of a cube

Length x Width x Height = Volume

$$8 \text{ ft} \times 4 \text{ ft} \times 2 \text{ ft} = 64 \text{ cubic feet}$$

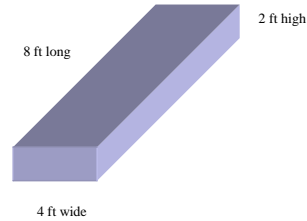

If the material was **cedar**, then all we would have to do to determine its weight would be to multiply the unit weight of cedar x 64.

Unit weight x Volume = Weight

$$34 \text{ lbs.} \times 64 \text{ cubic ft.} = 2,176 \text{ lbs.}$$



OBJECTIVE: To demonstrate how to calculate the volume of a cube.

1. Cubes are easy to calculate.
2. Finding the weight is as simple as multiplying the volume of the cube by the unit weight of what it is made of.

CALCULATING VOLUME

Volume of a cylinder

Pi x Radius Squared x Length = Volume

$\pi \times \text{Radius}^2 \times \text{Length} = \text{Volume}$

$3.14 \times 1^2 \text{ ft} \times 10 \text{ ft} = 31.4 \text{ cubic ft}$

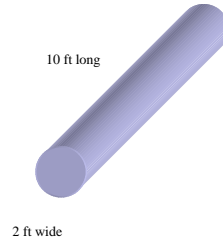

If the material was **reinforced concrete**, then all we would have to do to determine its weight would be to multiply the unit weight of reinforced concrete x 31.4.

150 lbs. X 31.4 cubic ft. = 4,710 lbs.



OBJECTIVE: To demonstrate how to find the volume of a cylinder.

1. The volume of a cylinder is a little more difficult, but not rocket science. Having a scientific calculator and knowing how to use it is a good idea.
2. Again, just multiply the volume in cubic feet by the unit weight to find the weight of the load.

CALCULATING VOLUME

Volume of pipe

Calculating the volume of pipe is a bit trickier but it is just simply subtracting the volume of the hole from the volume of the pipe.

If the pipe were one inch thick, three feet wide and 8 feet long, then we would figure the volume of the entire pipe and subtract the volume of the hole to get the volume of the material.

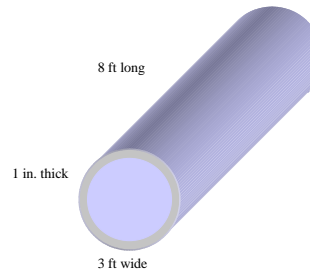

$$3.14 \times (1 \frac{1}{2} \text{ ft.})^2 \times 8 \text{ feet} = \text{total volume of pipe (56.52 ft}^3\text{)}$$

$$3.14 \times (1 \text{ ft } 5 \text{ in.})^2 \times 8 \text{ feet} = \text{volume of hole (50.41 ft}^3\text{)}$$

$$56.52 \text{ ft}^3 - 50.41 \text{ ft}^3 = 6.11 \text{ ft}^3$$

Volume of material x unit weight = total weight

If this pipe were **steel** then the unit weight would be 490 lbs.

$$6.11 \times 490 \text{ lbs} = 2,999.4 \text{ lbs.}$$



OBJECTIVE: To demonstrate how to find the volume of a pipe.

1. Finding the volume of a pipe is not too much different than finding the volume of a cylinder. You just have to do it twice and then subtract the volume of the hole from the total volume of the pipe.
2. It is helpful to know how to change fractions into decimals. Calculators are a must for this. To change 1 foot 5 inches (or 17/12ths) into a decimal, simple divide 12 into 17 which would be 1.4266.

CALCULATING VOLUME

For thin pipe a quick way to ***ESTIMATE** the volume is to split the pipe open and calculate the volume like a cube. The formula would be:

$\pi \times \text{diameter} = \text{width}$, so:

$\pi \times \text{diameter} \times \text{length} \times \text{thickness} \times \text{unit weight} = \text{weight of object}$

$3.14 \times 3 \text{ ft} \times 8 \text{ ft} \times 1/12 \text{ ft (or .08 ft)} \times 490 \text{ lbs} = *3,077.2 \text{ lbs}$

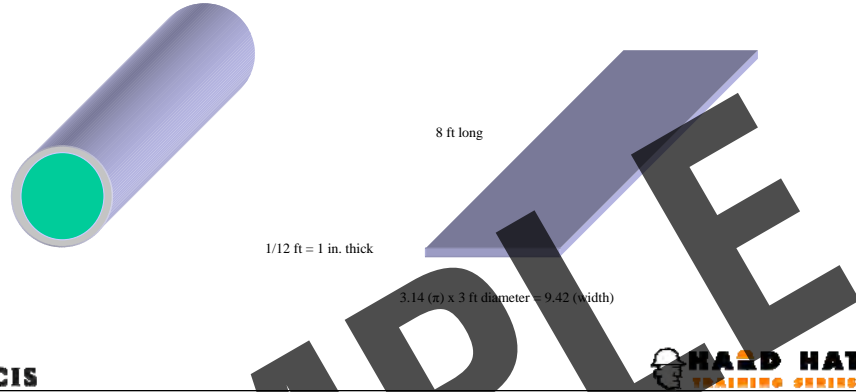

OBJECTIVE: To demonstrate how to estimate the volume of thin pipe.

1. This is only an estimate and should not be used with thick pipe.
2. Simply spit the pipe down the middle and open it up into a thin plate.
3. Then calculate the the volume of the cube that is created.
4. To find the width, multiply pi times the diameter.

WEIGHT TABLES

WEIGHT TABLES

Weight tables are an excellent way to calculate load weight. If you are handling certain materials often, then having a chart that gives you the weight per cubic foot, cubic yard, square foot, linear foot or per gallon. Here are a few examples:

METAL PLATES

STEEL PLATES weigh approximately 40 lbs per sq. ft. at 1 inch thick. 1/2 inch thick would then be about 20 lbs. per sq. ft.

A steel plate measuring 8 ft. x 10 ft. x 1/2 inch would then weigh about 3,200 lbs. (8 x 10 x 40 lbs = 3,200 lbs.)

BEAMS

Beams come in all kinds of materials and shapes and lengths. STEEL I-BEAMS weigh approximately 40 lbs a linear ft. at 1/2 inch thick and 8 inches x 8 inches. If it were 1 inch thick then it would be 80 lbs a linear ft. If it were 20 feet long at 1 inch thick then it would weigh about 1,600 lbs. (20 ft. x 80 lbs. = 1,600lbs.)



OBJECTIVE: To encourage the use of weight tables for determining the weights of loads.

SAMPLE