

TRENCH SAFETY TRAINING



TRENCH SAFETY TRAINING

- TRENCHING ACCIDENTS ACCOUNT FOR MORE THAN 100 DEATHS A YEAR ON U.S. SOIL.
- 11 TIMES MORE WORKERS ARE INJURED
- 1% OF ALL CONSTRUCTION ACCIDENTS
- INJURY RATE FOR TRENCHING WORK 112% HIGHER THAN CONSTRUCTION WORK IN GENERAL
- CRIMINAL PENALTIES ARE FREQUENTLY ASSESSED FOR NON-COMPLIANT COMPANIES WHEN SOMEONE IS KILLED OR INJURED

What is wrong with this picture?



2



“Officials Probe Workers Death in Excavation Cave-in”

Houston Chronicle

March 23, 1998

Summary: Local and federal officials are investigating the death of a 43 year old construction worker buried alive when the 18-foot deep trench in which he was working collapsed. The excavation was part of a sewer sanitation rehabilitation project just east of downtown Houston. Although a steel trench box was in place in the excavation, the worker was in the trench but outside of the trench box at the time of the cave-in. Co-workers on the street scrambled into the pit and frantically dug the dirt away from the face of the man, who was buried about six minutes. When firefighters arrived, they found the man conscious and were able to feed an oxygen line to him. As rescue work was in progress, a second cave-in occurred, trapping two firefighters who were trying to help. The second collapse also covered up the victim, and he died a few minutes later.

What went wrong?

- **Employee outside the box**
- **Second slide precipitated by the rescue effort causing the death**
- **Safety imperative during a rescue**
- **60% of confined space deaths are the “rescuers”**



Considerations determining trench safety:

- **Depth and width of trench**
- **Soil classifications**
- **Groundwater seepage; saturated or submerged soils**
- **Nearby utilities, services, or structures to be supported**
- **Surcharge loads; stored material, equipment, traffic, spoil, etc.**
- **Vibrations anticipated**
- **Working space requirements; size of pipe, bedding, etc.**
- **Changes in weather; rain, freeze and thawing, etc.**

It is these considerations that will determine the selection of a safe and productive trench safety system.

August 25, 1999

Contractor fined for willful violations in Lynnwood, WA worker death

TUMWATER, WA -- The Department of Labor and Industries has fined an Arlington, WA contractor more than \$172,000 for willful violations of safety rules in connection with the death of a 28-year-old utilities worker in a trench last March.

The agency cited DLR Utilities of Arlington for six willful, four serious and four general violations of regulations intended to protect workers from hazards found at trenching and excavation worksites. Penalties totaling \$172,640 were assessed.

Guy R. Daggett of Arlington suffered fatal injuries March 1, 1999 when he was caught between the wall of a trench and the bucket of an excavator that he was using for access into the 12-foot-deep trench. The trench was part of a sewer installation project in a residential section of Lynnwood.

Willful violations indicate that the employer knowingly or intentionally violated worker-protection rules, or exhibited plain indifference that a violation was occurring and failed to take corrective action.



Specifically, the company **willfully**:

- Failed to ensure that a competent person was assigned to the jobsite to assure the safety of the employees working in the trench. Additionally, the employer failed to ensure that adequate precautions were taken to protect employees working in trenches with accumulated water – which increases the probability of a trench cave-in. **(\$28,000 penalty)**
- Failed to ensure that employees working in trenches up to 13 feet deep were protected from potential cave-ins. In one instance where shielding was used, it was not used in accordance with the manufacturer’s specifications. **(\$28,000)**
- Failed to ensure that employees working in trenches up to 13 feet deep had safe means to enter and exit the trench. Employees rode the bucket of the excavator, a practice prohibited by industry standards and the manufacturer’s safe operating specifications. **(\$28,000)**
- Failed to ensure that employees working in trenches up to 13 feet deep were protected from the collapse of undermined sidewalks, pavements and other overhead hazards. In one instance, workers attempting to fix a natural gas leak in a trench were exposed to potential serious or fatal injuries from an overhanging pavement that was undermined and in danger of breaking loose and falling on them. **(\$24,000)**
- Failed to provide training to improve the skill and ability of employees to safely work on underground utility construction projects. Workers were left to independently determine safe methods based on experience. As a result, employees routinely were exposed to hazardous conditions, including trench-wall collapse, falls, hazardous atmospheres, overhead hazards, objects falling into trenches and motor vehicle traffic. **(\$28,000)**
- Failed to meet multiple requirements when workers are exposed to the hazards of confined spaces. Confined-space hazards include engulfment, asphyxiation, electrocution, and creation of flammable atmosphere. **(\$28,000)**

DLR Utilities also was cited for four **serious violations**, including:

- Failure to ensure that a method was in place – prior to the beginning of work – for the prompt and safe removal of injured employees from trenches and excavations. **(\$3,600)**
- Failure to ensure that workers were protected from the hazard of excavated materials, equipment and other materials falling into the trench. **(\$3,000)**
- Failure to medically evaluate two employees exposed to blood following the fatal incident. The regulation is intended to mitigate the risk associated with potential exposure to bloodborne diseases. **(\$1,020)**
- Failure to ensure that equipment involved in a fatality or probable fatality was not moved until authorized by an L&I representative. **(\$1,020)**

The employer also was cited for four **general violations** relating to deviating from manufacturer's specifications, accident prevention programs and hazardous chemicals. No penalties were assessed for these violations.

The employer has 15 working days from receipt of the violation report to appeal.

QUIZ

Trench accidents occur:

- Mostly in the Midwest
- In sandy types of soils
- Anywhere in all types of soils.

Trench collapse occurs:

- After the trench has been open for period of time
- Very quickly with little or no escape time
- Slow enough to escape.

Trench collapse usually results in:

- Minor injuries
- Moderate injuries requiring medical attention
- Critical injuries and often death

How can a trapped worker die if only buried to the chest?

- Exposure to the elements
- Suffocation from soil pressure
- Leg cramps

THE COMPETENT PERSON

OSHA defines a 'competent person' as: *“one who is capable of identifying existing and predictable hazards in the surroundings, or working conditions which are unsanitary, hazardous, or dangerous to employees, and who has authorization to take prompt corrective measures to eliminate them.”*

OSHA does not explicitly define training requirements, but the competent individual must have a knowledge of soils, protective systems and the standards. Having such knowledge, the competent person must be capable perform his duties and be authorized to stop work until any corrective measures are taken.



Before workers are allowed to enter an excavation the competent person must evaluate the excavation and specify what type of protective systems will be required.

The competent person is also required to monitor the conditions at the excavation and make necessary changes.

PROTECTIVE SYSTEMS

Is a Protective System Required?

Is the excavation more than 4 feet in depth?			
NO		YES	
Is there potential for a cave-in?		Is the excavation entirely in stable rock?	
YES	NO	YES	NO
Excavation must be sloped, shored, or shielded.	Excavation may be made with vertical sides.	Excavation must be sloped, shored, or shielded.	

SHORING

Shoring means a structure such as a metal hydraulic, mechanical or timber shoring system that supports the sides of an excavation and which is designed to prevent cave-ins.



PROTECTIVE SYSTEMS

SHORING is the provision of a support system for trench faces used to prevent movement of soil, underground utilities, roadways, and foundations. Shoring or shielding is used when the location or depth of the cut makes sloping back to the maximum allowable slope impractical. Shoring systems consist of posts, wales, struts, and sheeting. There are two basic types of shoring, timber and aluminum hydraulic.



TIMBER SHORING



HYDRAULIC SHORING

PROTECTIVE SYSTEMS

HYDRAULIC SHORING The trend today is toward the use of hydraulic shoring, a prefabricated strut and/or wale system manufactured of aluminum or steel. Hydraulic shoring provides a critical safety advantage over timber shoring because workers do not have to enter the trench to install or remove hydraulic shoring.



Other advantages:

- Are light enough to be installed by one worker;
- Are gauge-regulated to ensure even distribution of pressure along the trench line;
- Can have their trench faces "preloaded" to use the soil's natural cohesion to prevent movement; and
- Can be adapted easily to various trench depths and widths.

PROTECTIVE SYSTEMS

SHIELD

Shield means a structure that is able to withstand the forces imposed on it by a cave-in and thereby protect employees within the structure. Shields can be permanent structures or can be designed to be portable and moved along as work progresses. Shields used in trenches are usually referred to as “trench boxes” or “trench shields.”



SLOPING

Sloping means a method of protecting employees from cave-ins by excavating to form sides of an excavation that are inclined away from the excavation so as to prevent cave-ins. The angle of incline required to prevent a cave-in varies with differences in such factors as the soil type, environmental conditions of exposure, and application of surcharge loads.

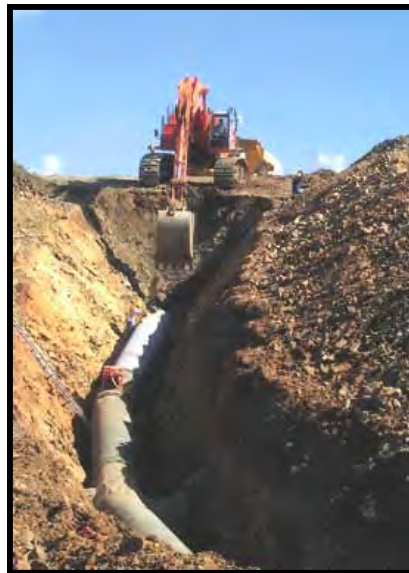

QUIZ

For which trench depth does a protective system need to be considered?

- a. Greater than 4 ft
- b. Greater than 20 ft
- c. Depends on the type of work being done

Which type of protective system protects the worker from a collapse .

- a. Shielding
- b. Shoring
- c. Sloping

Which type of protective systems prevent a collapse from starting?

- a. Shielding
- b. Shoring
- c. Sloping

OSHA REGULATIONS 29 CFR 1926 Subpart P *'Excavations'*

- **Addresses General Protection Requirements**
- **Specifies Protective Systems Requirements**
- **Soil Classification**
- **Sloping and Benching Requirements**
- **Shoring and Shielding Requirements**
- **Hazardous Atmosphere Requirements**

SOIL CLASSIFICATION

WHAT IS SOIL?

Cohesiveness depends on the mix of ingredients.

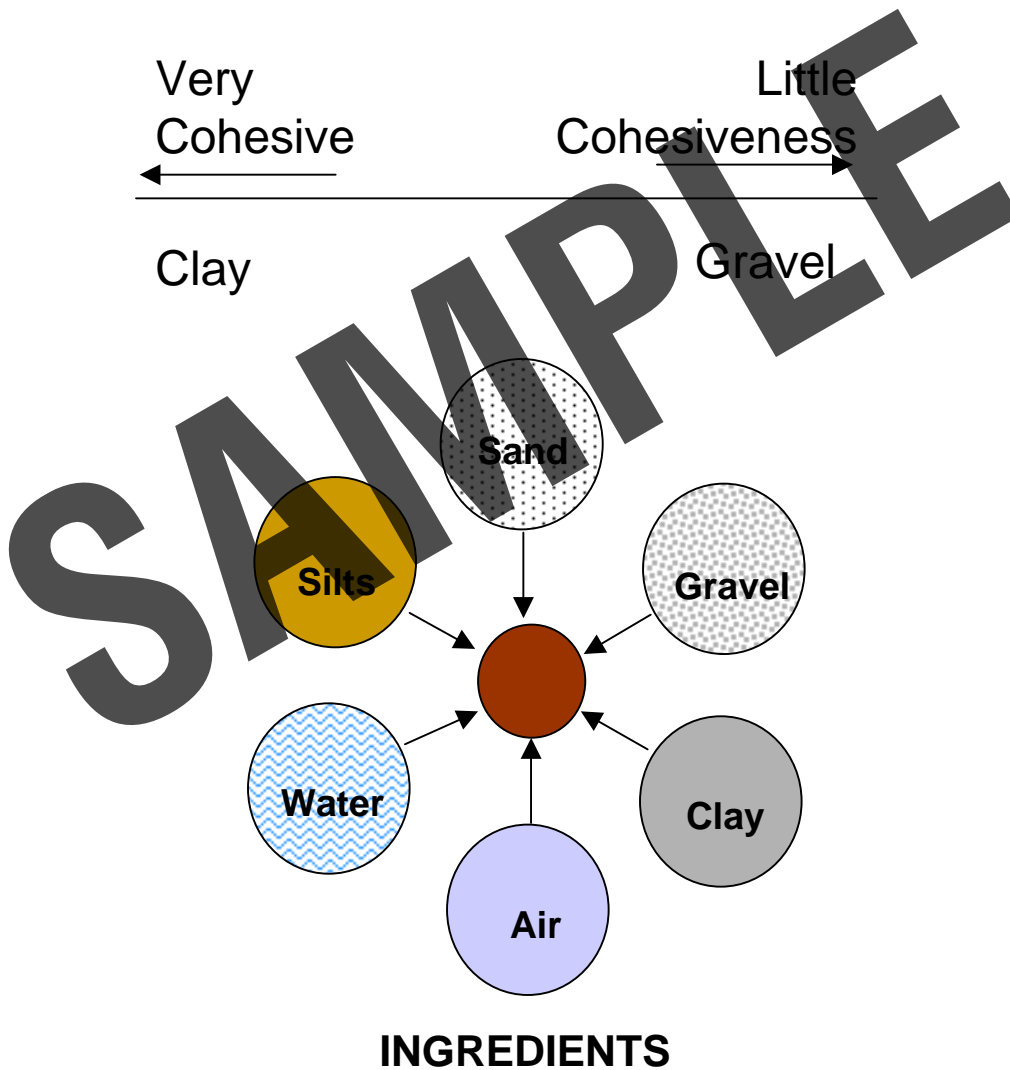

Typically, the more cohesive the soil, the stronger the trench wall.



SOIL CLASSIFICATION

**SOIL CLASSIFICATION IS TO BE DETERMINED
BY THE COMPETENT INDIVIDUAL**

BASIC SOIL TYPES

- **Stable Rock:** Stable mineral matter
- **Type A Soils:** Cohesive soils made up of clay, silty clay, sandy clay, clay loam, silty or sandy clay loam
- **Type B Soils:** Cohesive soils made up of angular gravel, silt, silt loam, or previously disturbed soils not classified as type C.
- **Type C Soils:** Cohesive soils made up of granular soils such as gravel, sand, loamy sand, soil with seeping water or unstable rock.

TEST METHODS

- **Penetrometer:** Instrument used to determine compressive soil strength of cohesive soils.
- **Dry Strength Test:** Method used to determine the composition of soil.
 - Granular
 - Clay in combination with silt, sand and gravel
 - Fissured/un-fissured

TEST METHODS

- **Thumb Penetration Test:** Procedure used to determine compressive soil strength of cohesive soils by using the thumb.
 - Makes indentation only with great difficulty, probably Type A
 - Makes penetration the length of the thumb nail, probably Type B
 - Makes penetration the length of the thumb, probably Type C

LEAST ACCURATE OF TEST METHODS

QUIZ

Major types of soils are:

- a. Clay and sand
- b. Sand, clay and gravel
- c. Silts and clay

Cohesive soils are:

- a. Primarily made up of gravel
- b. Primarily made up of clay
- c. Combination of sand and gravel

Determining the soil type is the responsibility of the:

- a. Worker
- b. Foreman
- c. Competent person

SOIL MECHANICS



All excavations will eventually slough until they reach their natural slope. The angle of the slope and the time to achieve this is dependent on several factors.

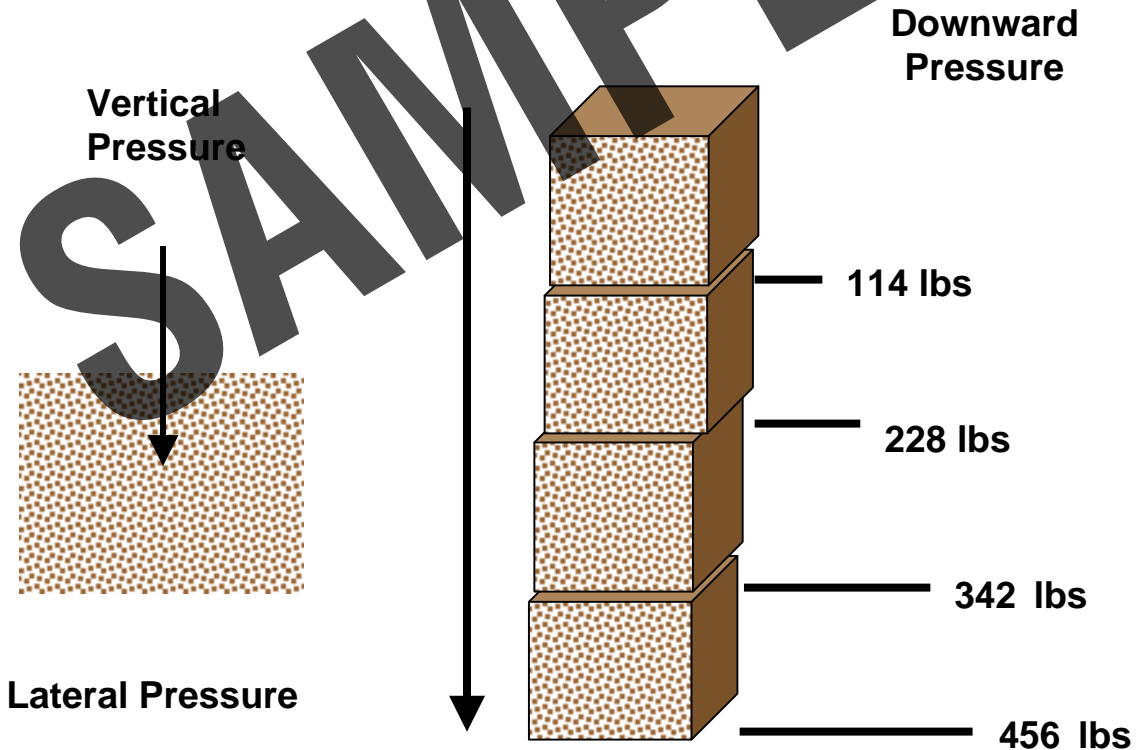

Lateral Pressure is $\frac{1}{3}$ to $\frac{1}{2}$ of vertical pressure

Soil weighs 114 lbs per cu. ft.

SOIL MECHANICS

TENSION CRACK

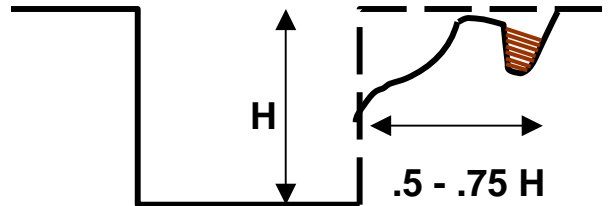

Cracks usually appear horizontally $.5 - .75$ times the trench depth from the edge of the cut.

SLIDING

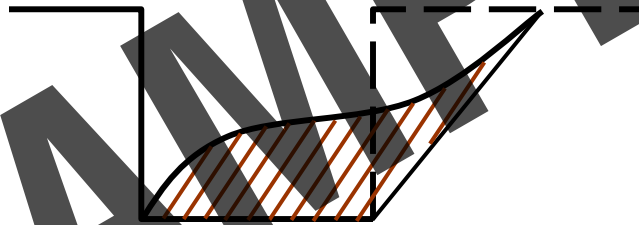

Sliding or sloughing may occur as a result of tension cracks.

TOPPLING

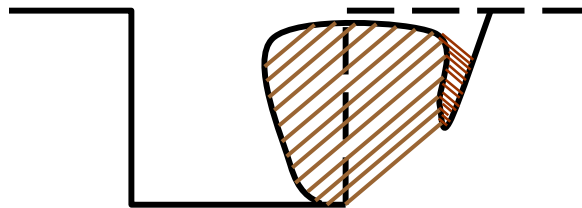

Caused by tension cracks toppling can occur when the trench's vertical face shears along a tension crack line and topples into the trench.

SOIL MECHANICS

SUBSIDENCE AND BULGING

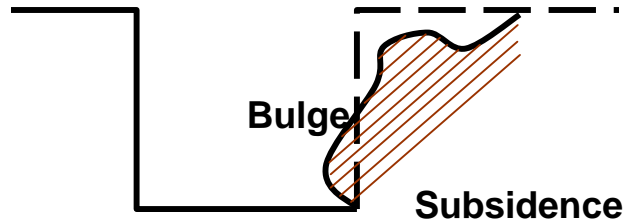

Subsidence or settling at the surface and bulging of the vertical face. Caused by unsupported trench.

HEAVING OR SQUEEZING

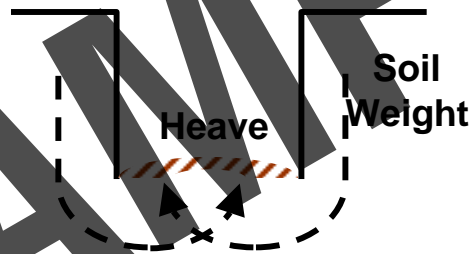

Caused by downward pressure created by weight of adjoining soil. May occur after the shoring or shielding has been properly installed.

BOILING

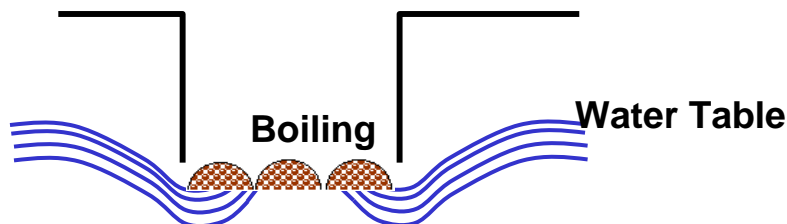

Evidenced by an upward water flow in the trench bottom typically caused by high water table. This can occur with shoring or shields installed.

TRENCH FAILURE

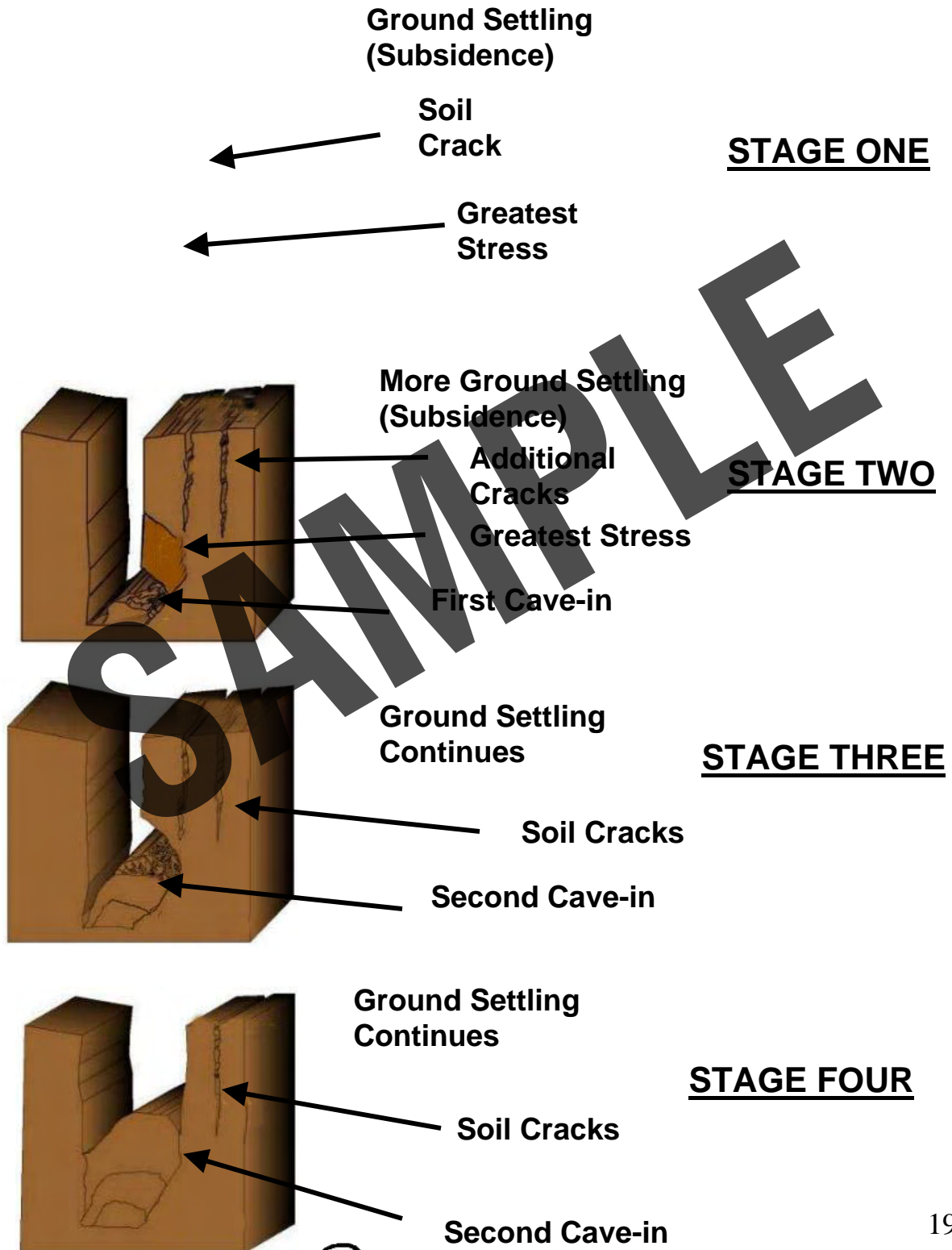

TRENCH FAILURE

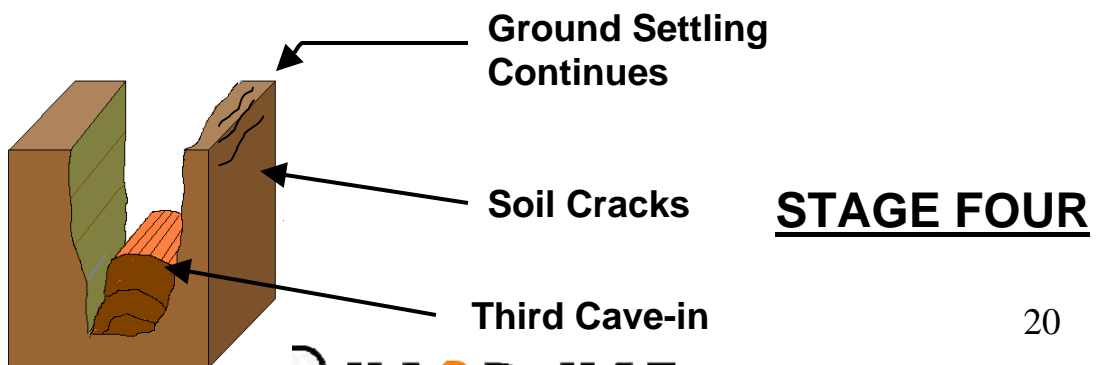
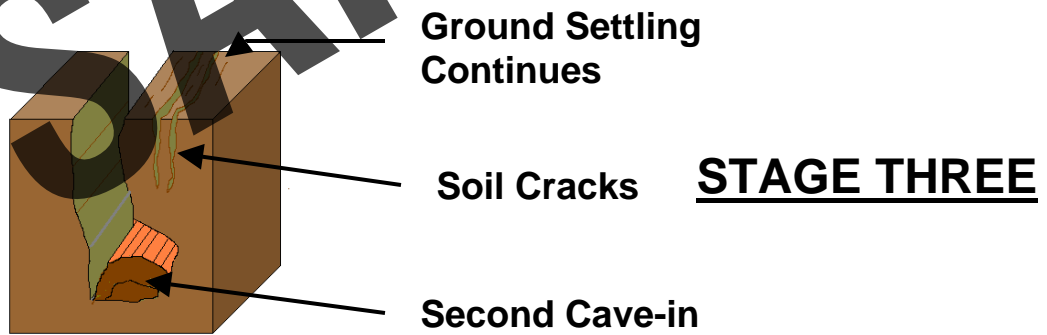
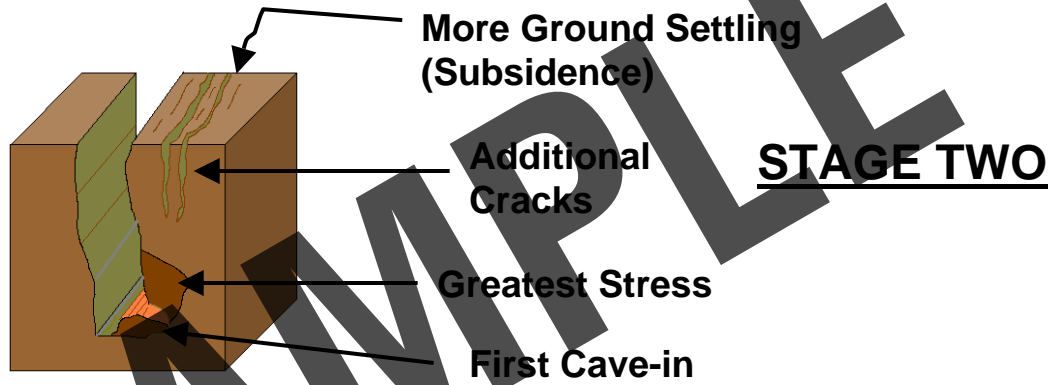
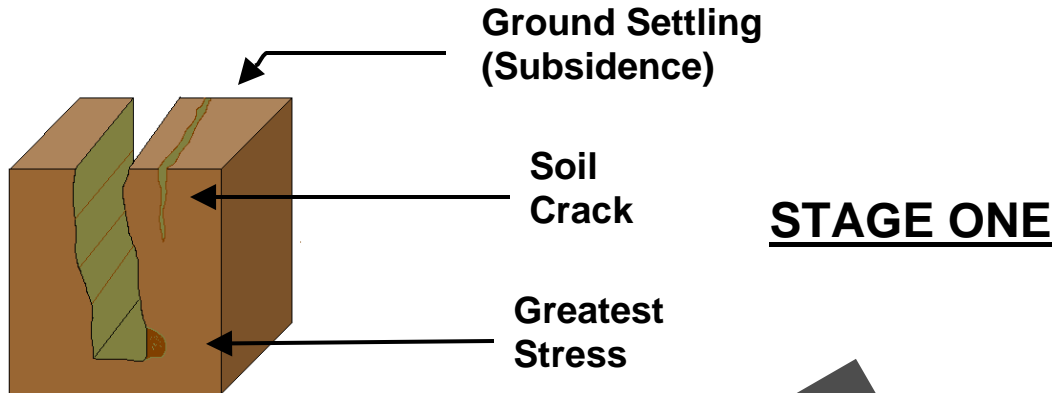

TRENCH FAILURE

Suffocation can occur from the pressure on the chest even though the victim's head is still visible.

400-800 lbs



QUIZ

Cave-ins generally occur:

- All at once
- In stages

The greatest area of stress in a trench is at the:

- Top of the trench
- Bottom of the trench

Trench walls that have water seeping from them tend to be

- Stronger than a dry trench wall
- Weaker than a dry trench wall

Cracks in the surface soil adjacent to the trench indicates

- The trench wall could collapse any moment
- The trench wall is settling and becoming stronger
- Doesn't mean anything

21



GENERAL TRENCH PRECAUTIONS

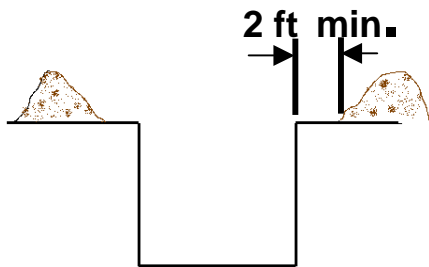

- Keep material & equipment 2 ft from edge of excavation.
- Provide barricades or equivalent to prevent people from falling into trench.

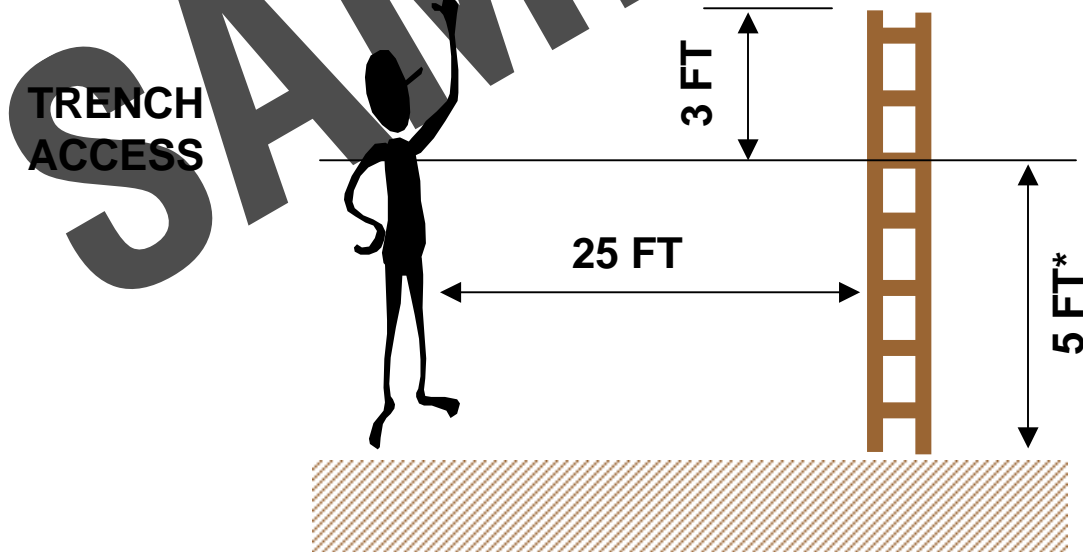

- Ladder must be secured and extend 3 feet above surface
- Ladder required when trench is over 5* feet deep
- Ladder must be within 25 feet of worker
- Non-metallic ladders recommended

* May vary dependent on state regulations.

GENERAL TRENCH PRECAUTIONS

- Workers in un-protected trench

- Machinery operating with workers in trench

- Vibrations from machinery increase chance of trench failure



QUIZ

Spoil removed from the trench needs to be placed a minimum of:

- a. 3 feet from the trench edge
- b. 4 feet from the trench edge
- c. 2 feet from the trench edge

For trenches over 4 feet deep:

- a. A ladder is required for going into and out of the trench
- b. The worker can ride the bucket into the trench
- c. There are no specific requirements

Vibrating machinery can:

- a. Increase the chance of a cave-in
- b. Help stabilize the surrounding soil
- c. Has no effect on the surrounding soil

SLOPING AND BENCHING

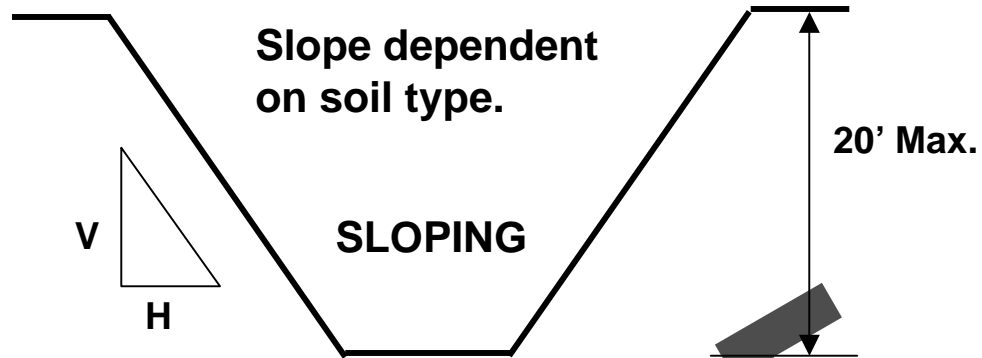

Soil or Rock Type	Max Allowable Slope
Stable Rock	Vertical (90 deg)
Type A	$\frac{3}{4} : 1$ (53 deg)
Type B	$1 : 1$ (45 deg)
Type C	$1 \frac{1}{2} : 1$ (34 deg)

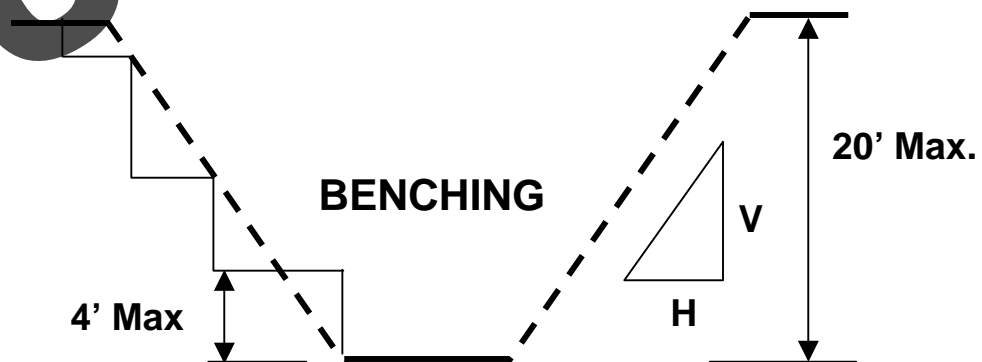

Sloping and bench are not widely used because of the amount of space required. Also, backfill and compaction are greatly increased.

TRENCH SHIELDS

Shields used in trenches are usually referred to as “trench boxes” or “trench shields.”

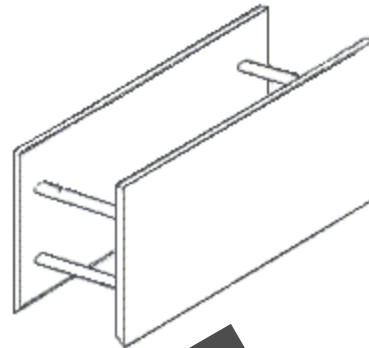

- Lay on side wall flat with connectors up.
- Insert spreader bars & plates and secure.
- Lift second side wall level using tag lines.
- Set side wall on spreader bars and secure.
- Use extreme caution when turning the shield upright.



INSPECTING TRENCH SHIELDS

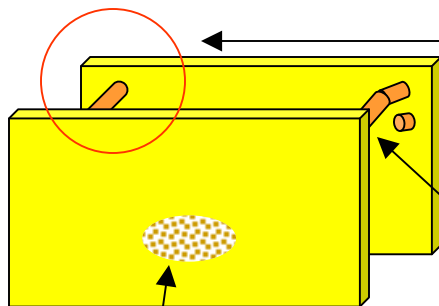

Missing, damaged fasteners

Dents, punctures, deformed sides

Bent, damaged
Missing spreader bars

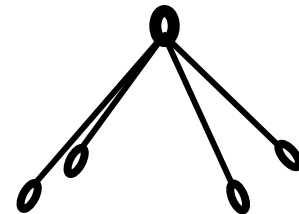

Inspect lifting rigging

LIFTING TRENCH SHIELDS



Know the weight of the shield



Know the lifting capacity of the machine

BACKHOE LIFT CAPACITY CHART

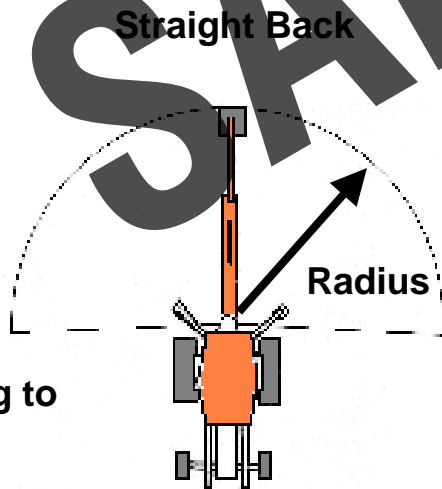

LIFT CAPACITY OF A BACKHOE

Radius	Capacity
Straight Back	
5 ft	8624 lbs
10 ft	5170 lbs
15 ft	3058 lbs
Swung to Side	
5 ft	7370 lbs
10 ft	3861 lbs
15 ft	2145 lbs

LIFTING TRENCH SHIELDS

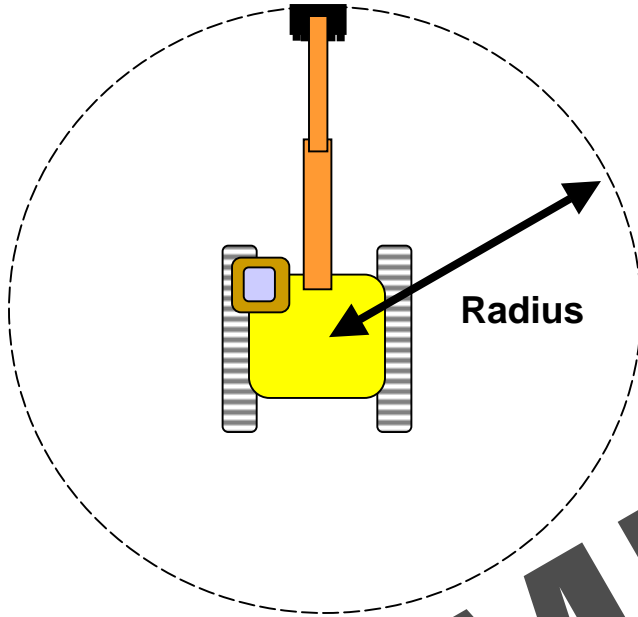

EXCAVATOR LIFT CAPACITY CHART

Radius	Capacity
10 ft	14000 lbs
15 ft	12000 lbs
20 ft	9000 lbs
25 ft	6000 lbs

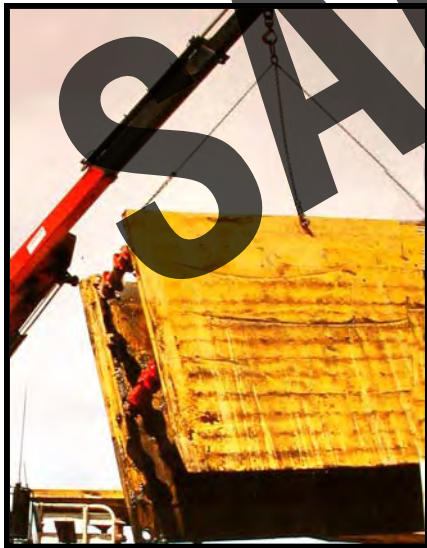

Load not level
with a 3 leg
bridle

- Lift Shields with a 4 leg bridle
- Keep a 60 degree sling angle
- Protect slings at sharp corners



TRENCH SHIELDS

SAFETY PRACTICES

- Follow the manufacturer's tabulated data information.
- Personnel should not work outside of the shield.
- When moving the shield, no workers in the trench.
- The top of the shield should extend a minimum of 18" above any material that could fall into the trench.
- Never stack shields that are not designed to do so.
- To prevent the shield from shifting if a cave-in occurs, back-fill the space between the shield and trench wall.

QUIZ

A trench shield:

- a. Prevents the trench wall from collapsing
- b. Protects the worker in case a collapse occurs

When using a trench shield, workers:

- a. Can be one foot outside of the shield
- b. Can be five feet if equipped with a harness & lanyard
- c. Should never should be outside the shield

The depth of a trench for which a shield can be used is determined from:

- a. Past experience
- b. Manufacturer's tabulated data information
- c. The shields are good for all depths

TRENCH SHORING



Whaler System



Vertical Hydraulic Shoring



Timber Shoring

HYDRAULIC SHORING The trend today is toward the use of hydraulic shoring, a prefabricated strut and/or wale system manufactured of aluminum or steel. Hydraulic shoring provides a critical safety advantage over timber shoring because workers do not have to enter the trench to install or remove hydraulic shoring.



Other advantages:

- Are light enough to be installed by one worker;
- Are gauge-regulated to ensure even distribution of pressure along the trench line;
- Can have their trench faces "preloaded" to use the soil's natural cohesion to prevent movement; and
- Can be adapted easily to various trench depths and widths.

29



TRENCH SHORING

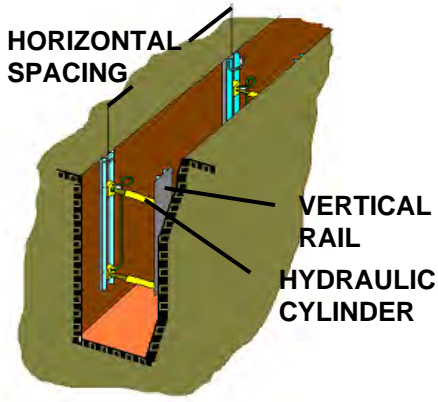

Vertical Aluminum Hydraulic Shoring

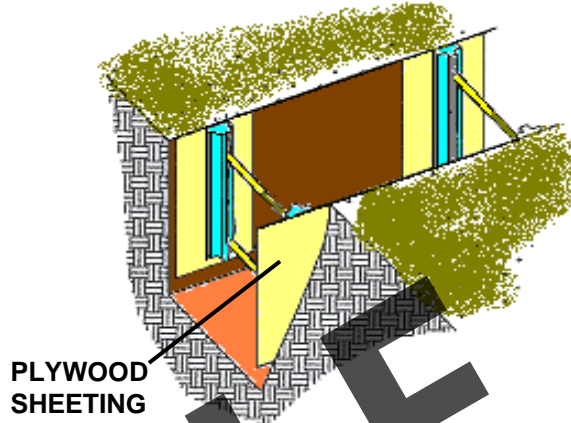

Vertical Aluminum Hydraulic Shoring w/ Plywood

SAMPLE

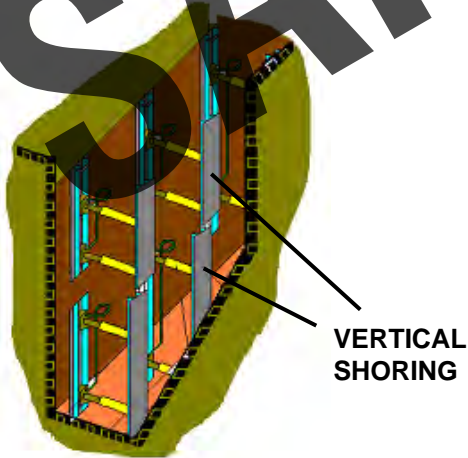

Vertical Aluminum Stacked Shoring

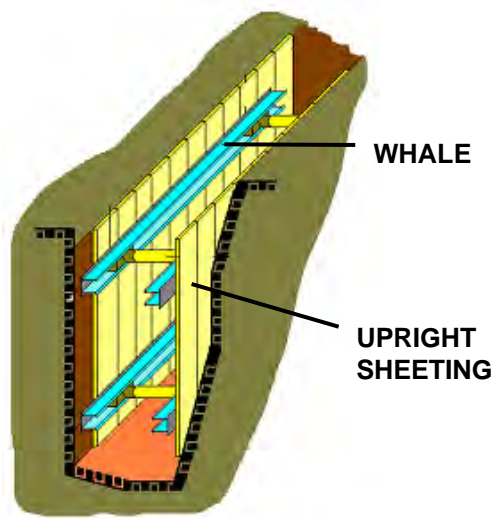

Aluminum Hydraulic Waler System

TRENCH SHORING

INSPECTIONS

- ✓ Dents & bends
- ✓ Crack welds
- ✓ Missing or damaged fasteners
- ✓ Damage or leaking hydraulic hoses
- ✓ Pump operation
- ✓ Proper hydraulic fluid
- ✓ Handling tools available

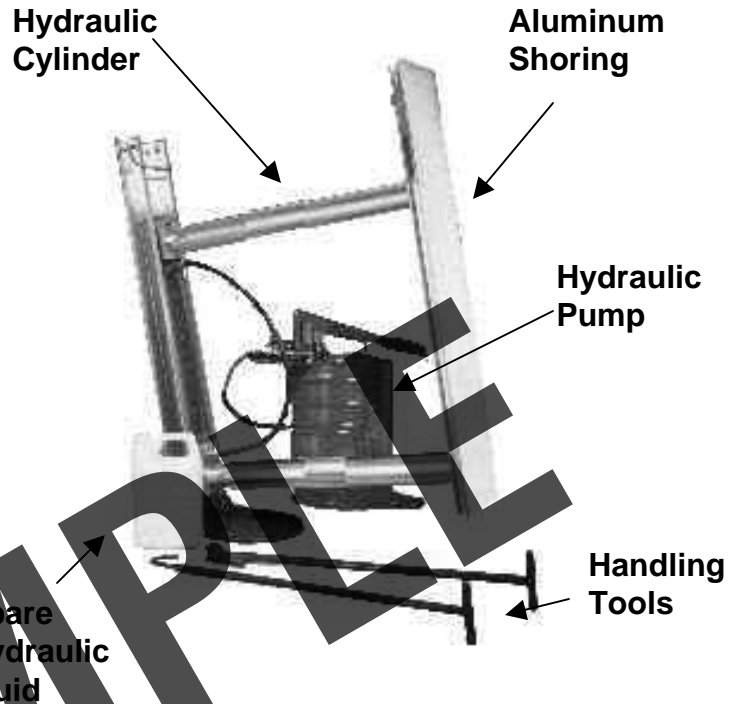

VERTICAL ALUMINUM SHORING



Installation is dependent on:

- Type of Soils
- Depth and width of trench
- Manufacturer's tabulated data information

TRENCH SHORING

INSTALLING VERTICAL ALUMINUM SHORING



- Connect hydraulic hoses to the pump.
- Place shoring at pre-determined intervals
- Place shoring using the installation tools from the top of the trench.



- Extend the hydraulic cylinders with the hydraulic pump.
- Using the gauge on the pump, increase pressure to the desired level.



- With shoring in place, use the release tool to disconnect the hydraulic hose.

TRENCH SHORING

REMOVING VERTICAL ALUMINUM SHORING



- Release hydraulic fluid at the hose fitting with the tool.
- Allow the shore cylinders to close.



- Pull the shore from the trench with the removal hook.



- Allow the shore to collapse when removing from trench.
- Fold flat for easy transportation.

TRENCH SHORING

QUIZ

When installing the vertical aluminum shoring, placement of the shoring is determined by:

- a. How many shores are available.
- b. How difficult it is to work around them.
- c. Manufacturer's tabulated data information.

When placing the vertical shoring into the trench:

- a. A worker should be in the trench to assist in the placement.
- b. The shoring should be installed from the top of the trench.
- c. It should be installed the fastest way possible.

The vertical shoring hardware should be inspected:

- a. Once a year
- b. Once a month
- c. Before each use

HAZARDOUS ATMOSPHERES



The competent person is responsible for determining the quality of the air in the trench.

Observe all precaution signs and requirements

TESTING REQUIREMENTS



- Trenches more than 4 feet deep must be tested.
- Where oxygen deficiency is suspected.
- Where toxic or flammable gases are may be present.

