



Welcome students to the class and see that each one has a student manual and a pencil.

- Emphasize the three main reasons for this training:
 1. Training reduces the risk of accidents and injuries to you and those you work with.
 2. Training reduces operating costs.
 3. OSHA requires it.



Scottsdale, Ariz.— A garbage truck sideswiped a boom lift aerial work platform while a worker was repairing a traffic signal. The collision threw the man from the personnel basket and killed him. When the operator fell from the basket, he hit his head on the bottom of the platform several times. According to reports, orange cones were in place around the intersection where the accident occurred.

This accident was indeed a tragedy. It appears that all safety precautions had been taken and personal protective equipment was being used. What caused the fatality was the long lanyard being used and tying off either to the railing or a connection point near the top railing. Using a shorter lanyard or tying off to an approved connection point lower down in the platform might have prevented this death.

During operation of a boom-supported aerial platform, the impact of another vehicle against it can cause the boom to flex and eject the operator. Take every precaution to prevent this from occurring.

WARNING: The railing is NOT approved as a connection point for your lanyard. Always use an approved connection point.

Review some of the other accidents in the Student Manual or from the Accident file provided on the CD. Pick those that might be closest to the types of machines and work your company is involved with.

WHAT IS A PROFESSIONAL?

- You've carefully thought out all the angles.
- You've done it a thousand times.
- It comes naturally to you
- You know what you're doing, its what you've been trained to do your whole life.
- Nothing could possibly go wrong.



SAMPLE

Think Again.



SAMPLE

WHY SAFETY TRAINING?

“You don’t play any better than you practice.”

Bud Wilkenson, University of Oklahoma football coach whose team won 47 consecutive games



“You don’t play any better than you practice.”

Bud Wilkenson, University of Oklahoma football coach whose team won 47 consecutive games

SAMPLE

TRAINING REQUIREMENTS

Only trained and authorized personnel must be permitted to operate the work platform. Before using the work platform, the operator must:

- (a) Read and understand the manufacturer's operating instructions and safety rules and be trained by a qualified person on the contents of the manufacturer's instructions and safety rules.
- (b) Read and understand all decals, warnings, and instructions on the work platform.
- (c) On a daily basis, before the work platform is used, it must be given a thorough inspection.



Know all federal, state and local rules which apply to your machine and jobsite. If you are not sure, ask your supervisor or safety coordinator.

29 CFR 1910.67

(c) (2) (ii) Only trained persons shall operate an aerial lift.

ANSI/SIA A92 – 1990

6.10 Operator Training. An owner who directs or authorizes an individual to operate an aerial platform shall ensure that the individual has been trained in accordance with the manufacturer's operating manual and requirements listed in Section 8 of this standard before operating the aerial platform.

TYPES OF AERIAL PLATFORMS



There are numerous types of self-propelled aerial platforms. These shown are just a representation of the most common ones.

This training is for general purposes and in no way replaces instructions in the aerial platform operator's manual.

TYPES OF AERIAL PLATFORMS

Articulated Boom
Aerial Platform

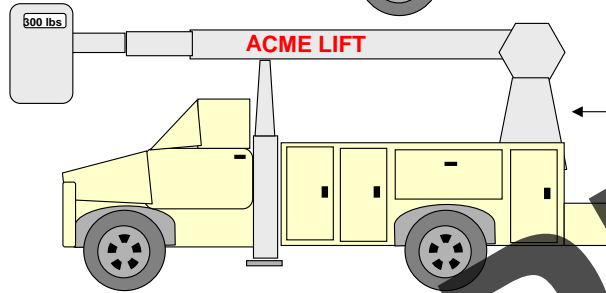
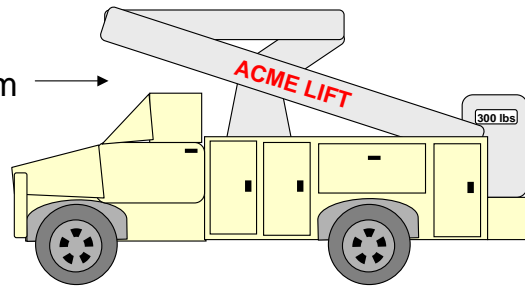

Telescopic Boom
Aerial Platform



SAMPLE

TYPES OF AERIAL PLATFORMS

Articulated and Telescoping Boom
Aerial Platform

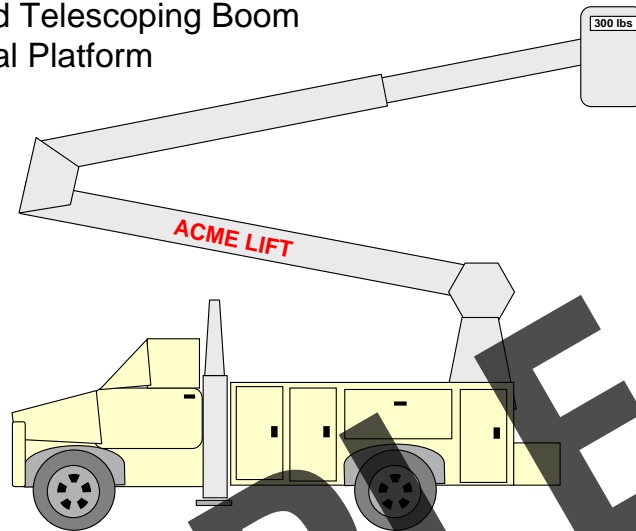

SAMPLE

TYPES OF AERIAL PLATFORMS

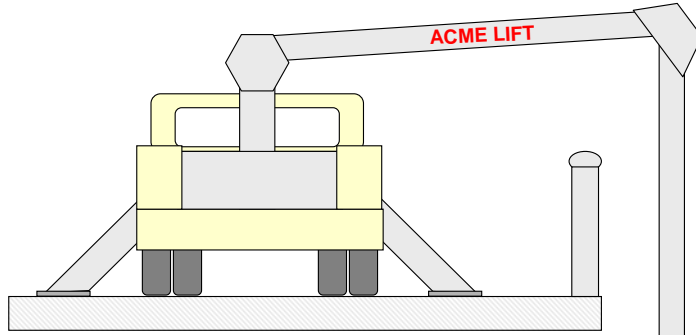

Articulated Boom
Bridge Inspection
Aerial Platform

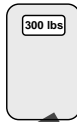

SAMPLE

INSPECTIONS

FREQUENT INSPECTION

Daily to monthly intervals

PERIODIC INSPECTION

One to twelve month intervals



ANSI/SIA A92.5 – 1992 6.5 Annual Inspections
ANSI/SIA A92.5 – 1992 6.6 Frequent Inspections
ANSI/SIA A92.5 – 1992 7.3.3 Pre-Start Inspections

SAMPLE

FREQUENT INSPECTIONS

The following tests and inspections shall be performed by the operator once daily, prior to first use, check:

- Operating controls and mechanisms for conditions interfering with proper operation.
- Visual and audible safety devices for malfunction.
- Hydraulic or pneumatic systems for observable deterioration or excessive leakage.
- Fiberglass and other insulating components for visible damage or contamination.
- Missing or illegible operational markings.
- Electrical apparatus for malfunction, signs or excessive deterioration, dirt, and moisture accumulation.



The following tests and inspections shall be performed by the operator once daily, prior to first use:

- Operating controls and mechanisms for conditions interfering with proper operation.
- Visual and audible safety devices for malfunction.
- Hydraulic or pneumatic systems for observable deterioration or excessive leakage.
- Fiberglass and other insulating components for visible damage or contamination.
- Missing or illegible operational markings.
- Electrical apparatus for malfunction, signs or excessive deterioration, dirt, and moisture accumulation.

FREQUENT INSPECTIONS

Any suspected items shall be carefully examined and a determination made by a qualified person as to whether they constitute a safety hazard. All unsafe items shall be replaced or repaired before use.



Any suspected items shall be carefully examined and a determination made by a qualified person as to whether they constitute a safety hazard. All unsafe items shall be replaced or repaired before use.

SAMPLE

PERIODIC INSPECTIONS

The following tests and inspections shall be performed by the operator on a periodic basis:

- Structural members for deformation, cracks or corrosion.
- Parts, such as pins, bearings, shafts, gears, rollers, locking devices, chains, chain sprockets, wire ropes and sheaves for wear, cracks or distortion.
- Hydraulic and pneumatic relief valve settings.
- Hydraulic system for proper oil level.
- Hydraulic pneumatic fittings, hoses, and tubing for evidence of leakage, abnormal deformation, or excessive abrasion.
- Compressors, pumps, motors and generators for loose fasteners, leaks, unusual noises or vibrations, loss of operating speed, and excessive heating.



The following tests and inspections shall be performed by the operator on a periodic basis:

- Structural members for deformation, cracks or corrosion.
- Parts, such as pins, bearings, shafts, gears, rollers, locking devices, chains, chain sprockets, wire ropes and sheaves for wear, cracks or distortion.
- Hydraulic and pneumatic relief valve settings.
- Hydraulic system for proper oil level.
- Hydraulic pneumatic fittings, hoses, and tubing for evidence of leakage, abnormal deformation, or excessive abrasion.
- Compressors, pumps, motors and generators for loose fasteners, leaks, unusual noises or vibrations, loss of operating speed, and excessive heating.

PERIODIC INSPECTIONS

- Hydraulic and pneumatic valves for malfunction and visible cracks in the external valve housing, leaks, and sticking spools.
- Hydraulic and pneumatic cylinders and holding valves for malfunction and visible damage.
- Hydraulic and pneumatic filters for cleanliness and the presence of foreign material in the system.
- Electrical systems and components for deterioration or wear.
- Performance test of all boom movements.
- Condition and tightness of bolts and other fasteners.
- Welds, as specified by the manufacturer.
- Legible and proper markings of controls, ratings and instructions.



- Hydraulic and pneumatic valves for malfunction and visible cracks in the external valve housing, leaks, and sticking spools.
- Hydraulic and pneumatic cylinders and holding valves for malfunction and visible damage.
- Hydraulic and pneumatic filters for cleanliness and the presence of foreign material in the system.
- Electrical systems and components for deterioration or wear.
- Performance test of all boom movements.
- Condition and tightness of bolts and other fasteners.
- Welds, as specified by the manufacturer.
- Legible and proper markings of controls, ratings and instructions.

RECORD RETENTION

Written, dated and signed reports shall be made of PERIODIC inspections and tests and retained for a period of five years.

Records of FREQUENT inspections need not be made. However, where a safety hazard is found, it shall be reported in writing to a person responsible for the corrective action and that report and a record of the correction shall be maintained for five years.

VEHICLE MOUNTED AERIAL PLATFORM INSPECTION & MAINTENANCE RECORD	
Company:	_____
Manufacturer:	_____
Model #:	_____
Serial #:	_____
Equipment ID:	_____
Equipment Location:	_____



ANSI/SIA A92.5 – 1992

5.9 Record retention for dealers

Dealer(s) shall retain the following records for at least three years:

- Name and address of the purchaser of each aerial platform by serial number and date of delivery.
- Records of the person(s) trained upon each delivery of and aerial platform.
- Records of the pre-delivery preparation performed prior to each delivery.

6.13 Record retention for owners

The owner shall retain the following records for at least three years:

- Name and address of the purchase of each aerial platform by serial number and date of delivery.
- Records of the person(s) trained upon each delivery of an aerial platform.
- Written records of the frequent and annual inspections shall be kept by the owner when he performs the inspection. The record shall include deficiencies found, corrective action and identification of the person(s) performing the inspection and repairs.
- Records of the pre-delivery preparation performed prior to each delivery.

7.6.2 Trainee records

A record of the trainee's aerial platform instructions shall be maintained by the user for at least three years.

MODIFICATIONS

No modifications or additions which affect the stability, mechanical, hydraulic, or electrical integrity or or the safe operation of the aerial device shall be made without the written approval of the manufacturer. If such modifications or changes are made, the capacity, operation, and maintenance instruction markings shall be changed accordingly. In no case shall the safety factors be reduced below those specified in this standard or below the manufacturer's design safety factors, whichever are greater.



No modifications or additions which affect the stability, mechanical, hydraulic, or electrical integrity or or the safe operation of the aerial device shall be made without the written approval of the manufacturer. If such modifications or changes are made, the capacity, operation, and maintenance instruction markings shall be changed accordingly. In no case shall the safety factors be reduced below those specified in this standard or below the manufacturer's design safety factors, whichever are greater.

PRE-OPERATION INSPECTION

INSPECT THE FOLLOWING COMPONENTS PRIOR TO OPERATION



Decals legible and in place
Engine fluids at correct levels
Electrical components & wiring
Hydraulic hoses, fitting, cylinders
Fuel & hydraulic tanks
Drive & turntable motors & drives
Boom extension cables & wear pads
Boom damage & dents
Tires & wheels
Engine & related components
Limit switches, alarms, horns, beacons
Nuts, bolts, & other fasteners
Platform rail & entry gate
Cracks in welds & structural components
Compartment covers in place & latched
Platform & ground control operations
Auxiliary power function

Perform any additional tests as prescribed by the manufacturer.



- Emphasize that the aerial lift is to be inspected before each day's use or at the start of each shift. A record of the inspection is recommended.
- The above checklist is for discussion purposes. The manufacturer typically can provide a more definitive checklist for a particular aerial platform.

ALSO:

ANSI/SIA A92.5-1992 7.8 states: Work place inspection

Before the aerial platform is used and during use, the user shall check the area in which the aerial platform is to be used for possible hazards such as but not limited to:

- a) Drop-offs or holes
- b) Bumps and floor obstructions
- c) Debris
- d) Overhead obstructions and high voltage conductors
- e) Hazardous locations
- f) Inadequate surface and support to withstand all load forces imposed by the aerial platform in all operating configurations
- g) Wind and weather conditions
- h) Presence of unauthorized persons
- i) Other possible unsafe conditions

OPERATOR'S MANUAL

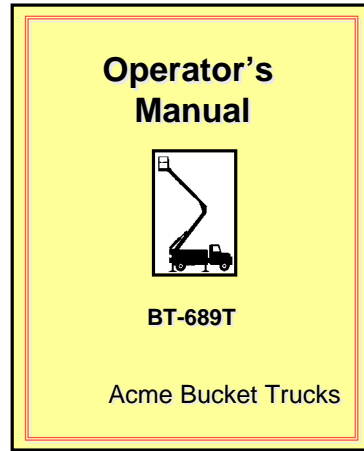

The manual is considered an integral part of the aerial platform and is vital to communicate necessary safety information to users and operators.



Maintenance and operating manuals requirement: An operating and maintenance manual(s) must be provided with each work platform and must contain:

- (a) Descriptions, specifications, and ratings of the work platform.
- (b) The maximum hydraulic and pneumatic system pressure and the maximum voltage of the electrical systems which are part of the work platform.
- (c) Instructions regarding operation and maintenance.
- (d) Replacement part(s) information.

Manual should be on the machine at all times.

ANSI/SIA A92.5 – 1992 7.2 Manuals. Users shall keep and maintain a copy(ies) of the operating and maintenance manual(s) required in 4.16.1 of this standard. The operating manual(s) shall be provided with each rental, lease or sale delivery and shall be stored in the weather resistant storage compartment require by 4.16.2 of this standard. **The manual is considered an integral part of the aerial platform and is vital to communicate necessary safety information to users and operators.** In addition, parts and maintenance manuals shall be provided with each sale delivery.

DECALS AND WARNING LABELS

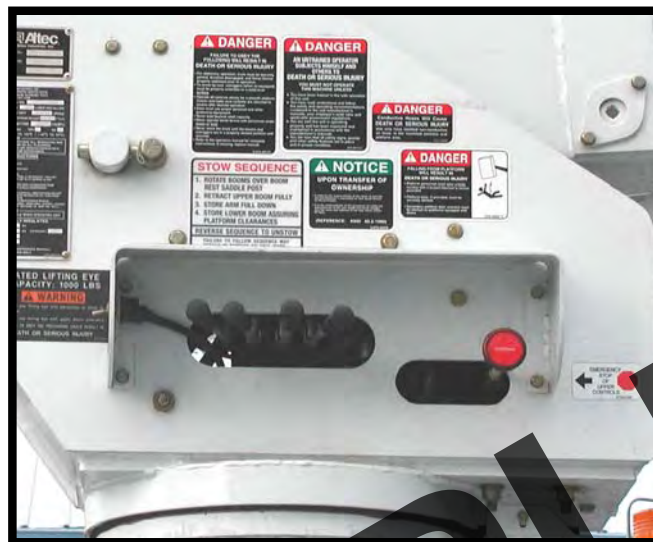

The following information must be displayed on all aerial platforms in as permanent and as visible a manner as practical:

- Warnings, cautions, or restrictions for safe operation
- Make, model, serial number, and manufacturer's name and address
- Rated workload
- Maximum platform height
- Nominal voltage rating of batteries or rated voltage of AC line
- Statement concerning the need of the operator's familiarity with the work platform before it is used
- A statement of whether or not the aerial platform is electrically insulated

The user shall verify that all nameplates and markings are in place and are maintained in a legible condition.

(COPY OF ANSI/SIA A92.6 – 1990 REGARDING DECALS AND WARNING LABELS REQUIRED TO BE ON THE MACHINE IS ON THE NEXT PAGE)

DECALS AND WARNING LABELS

ANSI/SIA A92.6 - 1990

Note: This section of the standard is almost identical to the one for Boom-Supported Elevating Work Platforms found in A92.5.4.18-1992. Although this information is intended for manufacturers, it helps owners to see what information must be maintained on the machine or replaced if damaged or illegible.

4.13 Instructions and Markings (for Self-Propelled Elevating Work Platforms)

4.13.1 **Manufacturer information.** The following information shall be displayed on all aerial platforms in a clearly visible, accessible area and in a durable manner

- (1) Warnings, cautions, or restrictions for safe operation and maintenance in accordance with ANSIZ35.1-1972;
 - (2) The make, model, serial number, and manufacturer's name and address.
 - (3) The rated work load, including rated number of occupants;
 - (4) The maximum platform height;
 - (5) The maximum travel height, if not equal to the maximum platform height;
 - (6) The nominal voltage ratings of the batteries if battery powered;
 - (7) A notice to study the Operating Manual before using the equipment;
 - (8) A notice of the inspections required by Section 6 of this standard.
 - (9) An alternative configuration statement. If an aerial platform may have several alternative configurations, the manufacturer shall clearly describe these alternatives, including the rated capacity in each situation. If the rated work load of the aerial platform is the same in all configurations, these additional descriptions are not necessary.
 - (10) If the multiple ratings are used, the following conditions shall be compiled with:
 - (a) When the rated workload varies according to multiple configurations of the aerial platform, the manufacturer shall clearly describe these configurations, including the rated workload of each, in the manual and on the platform. Examples of alternated configurations are, but shall not be limited to, the following:
 - (i) Outriggers or stabilizers extended to firm footing versus not extended;
 - (ii) Platform and extensions(s) extended versus retracted;
 - (iii) Platform attachment(s) attached versus unattached;
 - (iv) Elevating assembly elevated versus lowered;
 - (v) Extendable axles extended versus retracted.
 - (b) When the rated workload of the alternate configuration depends on the location of the platform in relation to the base, the manufacturer shall display the appropriate rated workload of the control station(s).
 - (c) Unrestricted rated workload shall be displayed at each access to the platform and operator control station(s).
 - (11) A statement of whether or not the platform or any portion thereof is electrically insulated. If equipped with an insulated platform, the level of protection and applicable test standard shall be stated, in accordance with ANSI/SJA A92.2-1990.
 - (12) Warnings against replacing, without manufacturer's consent, components critical to machine stability, i.e. batteries or ballasted tires, with lighter weight components. The minimum weights of such components shall be specified.
- A statement of compliance with section 4 of this standard.

RATED LOAD



The rated load must be visible to the user. The difference between a 2 person and a 3 person platform can be critical for the stability of the machine. This load rating includes the weight of all occupants, their tools, and all materials.

Before raising the platform, disperse the load evenly, making sure that nothing is interfering with any of the controls. Do not carry materials on railings unless railings are approved for that purpose. Do not, at any time, add a load that exceeds the rated capacity of the machine. Do not carry overhanging loads unless approved by the manufacturer.

ANSI/SIA A92.5 – 1992 8.10.7 Capacity Limitations. Rated capacities shall not be exceeded when loads are transferred to the platform at any height.

ELECTRICAL COMPONENTS

Check for damaged or loose electrical wiring and components.

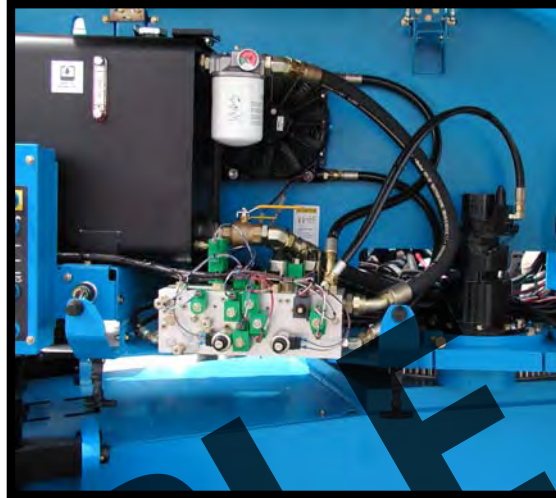

Any damaged or loose electrical wiring or components should be repaired immediately. Keep such components free from dirt and grease.

GROUND CONTROLS

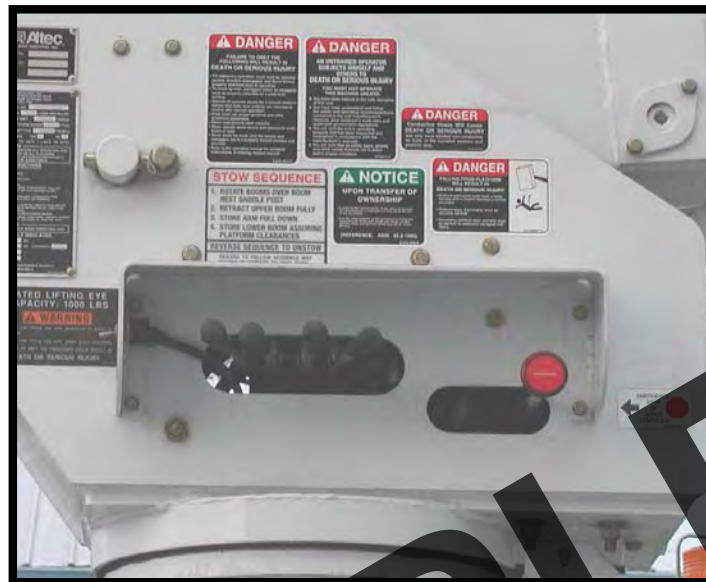

Know your equipment.

Know the purpose of all ground controls. Make sure you know what to do if the operator on the platform cannot get himself down.

Make sure all control labels are in place and legible.

Make sure that all controls do what they are labeled to do.

STABILIZER SECTION

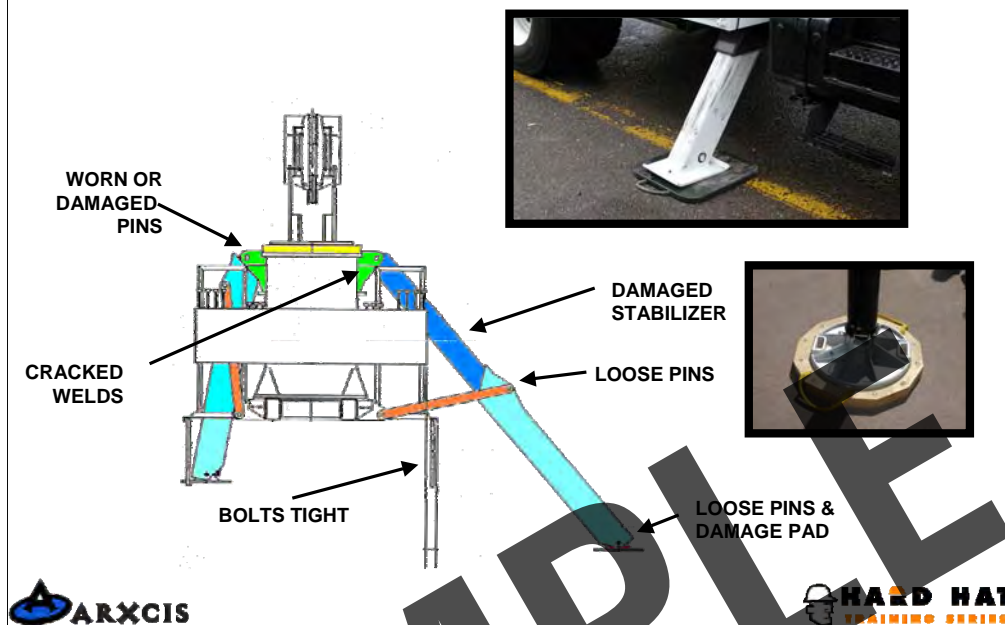

1. When the stabilizer is deployed it should extend smoothly.
2. Check for any dents or deformity in the box tubes.
3. The pads should not be bent up on the corners and should move freely on the hinge pin. Check to see that the pin keepers are present and that there is no excessive play in the pin area.
4. The upper hinge pin and bushing can be check by lowering the stabilizer within a few inches of the ground and moving it back and forth. There will be some movement but excessive wear in this area needs to be repair. Excessive wear will allow the vehicle to rock for and aft when making a lift and cause further damage.
5. All welds associated with the structure need to be check for cracks.
6. The attachment of the lift to the truck chassis needs to be checked. If bolted, check around the bolt heads and washer area to see if there is cracked paint or dirt which could indicate movement.

CHASSIS & TURNTABLE

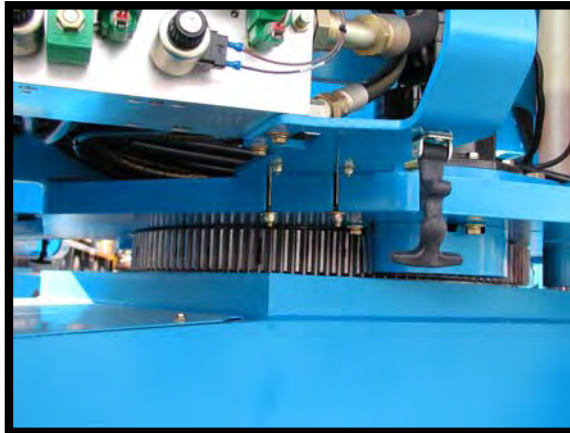

Check swing motor for loose bolts, damaged gears.

Check turntable base and chassis for objects left there.



The swing motor and bearing need to be checked for wear.
All parts need to be lubricated often.
Worn bearings or pinion gears can cause sloppy handling.

SAMPLE

TURRET SECTION



1. The four areas identified in the slide can be checked by performing the following functional test.
 - A. Set up the vehicle on level ground with the stabilizers fully extended.
 - B. Retract the boom fully.
 - C. Raise the boom to its most vertical position .
 - D. Abruptly lower the boom momentarily which will result in the turret and boom component rocking. Observe the vertical movement in the rotation bearing, boom hinge pin and bushing, and the lift cylinder pins and bushings.
2. Any excessive movement must be noted and evaluated per manufacturer's specifications.
3. Check the turret area for cracked welds and any deformed components.

HYDRAULIC CYLINDERS

Check the lift cylinders for hydraulic leaks and other damage.



Hydraulic lines are under tremendous pressure. Suspected leaks should be checked with a piece of cardboard. Never use a bare hand. Goggles are recommended.

A thin film of fluid on a lift cylinder rod is not a cause for concern. This can be caused by a worn wiper seal. If it turns into a drip, then it should be investigated more thoroughly.

INSPECTING THE BOOM



Inspect for dents and other damage.



The boom is like a tin can, very strong until it gets a dent on the side. Any dents should be checked with the specifications from the manufacturer and repaired as needed.

You must assume your machine is NOT electrically insulated unless it is specifically indicated on the machine rating plate.

Electrically insulated booms must be dielectrically tested often. Many factors can contribute to a failure of this test including a dirty machine, contaminated hydraulic oil or cracks in the boom finish.

Always keep your machine clean and free of excessive dirt and grease.

On the boom, look for leaks that may indicate leaky hydraulic cylinders.

Check slide pads for wear and adjust them when needed.

BUCKET STRUCTURE

Check hinge for smooth operation.

Check hoses for chafing and other damage.



The load rating should be clearly visible to anyone who enters the platform.

There should be an anchorage point for a lanyard that is clearly marked so the operator knows not to tie off somewhere else.

Any hoses that go over a sharp edge should be covered with chafing gear or softeners.

Check hinge pins and bushings for looseness and/or wear.

BUCKET CONTROLS

All directional controls must be marked for the direction they control and must be of the type which automatically returns to the “off” or neutral position when released.



All directional controls must be marked for the direction they control and must be of the type which automatically returns to the “off” or neutral position when released.

Controls must be protected against inadvertent operation.

Check emergency controls to make sure you are able to descend if the vehicle is turned off and cannot be restarted.

FUNCTIONAL TEST

PRIOR TO PUTTING THE MACHINE INTO SERVICE,
ENSURE ALL THE FUNCTIONS ARE PROPERLY WORKING.



Ground controls:

- Activate Emergency Stop
- Activate each boom function
- Test auxiliary controls



Platform controls:

- Activate Emergency Stop
- Test horn
- Test foot switch
- Test boom and platform functions
- Test auxiliary controls

Perform any additional tests as prescribed by the manufacturer.



After starting, recheck all gauges and lights. Check the audible and/or visual alarms (if provided). Make sure everything is functioning correctly. Check all control functions, including the emergency stop mechanism at the upper and lower control stations. If the aerial controls do not respond properly when operated, do not use the machine until it is fixed.

Move slowly until you are certain everything is operating properly. Be certain that boom travel is smooth and ceases when the controls are released. Be certain you can lower an elevated platform.

REPAIRS AND MAINTENANCE

Aerial platforms that are not in safe operating condition must be removed from service until repaired.

Repairs must be made by a qualified person in compliance with the manufacturer's operation and maintenance manuals.

Modifications or alterations of aerial platforms must be made only with written permission of the manufacturer or an other equivalent entity.



ANSI/SIA A92.6-1990

6.7 Maintenance Safety Precautions. Before adjustments and repairs are started on an aerial platform, the following precautions shall be taken as applicable:

- (1) Power plant stopped and starting means rendered inoperative
- (2) All controls in the "off" position and all operating systems secured from inadvertent motion by brakes, blocks, or other means.
- (3) Elevating assembly and platform lowered to the full down position, if possible, or otherwise secured by blocking or cribbing to prevent dropping
- (4) Hydraulic oil pressure relieved from all hydraulic circuits before loosening or removing hydraulic components.
- (5) Safety props or latches installed where applicable as prescribed by the manufacturer.

6.8 Replacement Parts. When parts or components are replaced, they shall be identical or equivalent to original aerial platform parts or components.

6.9 Maintenance Training. The owners shall train their maintenance personnel in inspection and maintenance of the aerial platform in accordance with 6.3, 6.4, 6.5, 6.6, 6.7, 6.8 and 6.10 of this standard, and with the manufacturer's recommendations.

6.14 Modifications. Modification or alteration of an aerial platform shall be made only with prior written permission of the manufacturer.

REPAIRS AND MAINTENANCE

Follow manufacturer schedule for maintenance and service.

MAINTENANCE SCHEDULE		
COMMENTS	SERVICE REQUIRED	RECOMMENDED LUBRICANT OR EQUIVED INSTRUCTIONS
DAILY MAINTENANCE (OPERATOR'S INSPECTION)		
Emergency Down System	Check Operation	
Oil Filter	Check Condition	
Engine Oil	Check Oil Level	
Engine Coolant	Check Fluid Level	
Fuel Lines	Visually inspect (leaks, Connections, etc.)	
Fuel Tank Cap	Visually inspect (operation)	
Engine Fuel Level	Check Fuel Gauge	
Belt and Insulators	Visually inspect (looseness)	
Platform Safety Gate	Visually inspect (operation)	
Equip Keys	Visually inspect (check Wear Mark)	
Structural Damage & Welds	Visually inspect (Weld Cracks, Spalls)	
Tires and Wheels	Visually inspect (Condition), Check Inflation	
Battery Fluid Level	Check Fluid Level	
Battery Terminals	Visually inspect (Corrosion)	
Charging System	Visually inspect (Belt, Gauge)	
Control Switches	Visually inspect (operation)	
Wiring Harnesses	Visually inspect (Installation, Condition)	
Hydraulic Leaks	Visually inspect (leaks, Treads)	
Hydraulic Oil	Check Fluid Level	
30 DAY OR 50 HOUR MAINTENANCE (QUALIFIED SERVICE TECHNICIAN)		
Electrical Connections	Visual Inspection, Complete Form	Refer Copy of Electrical
Chassis	Visual Inspection, Complete Form	Refer Copy of Electrical
Powertrain & Safety Inspection	Performance Inspection, Complete Form	Refer Copy of Electrical
Chert		
Door Hinges & Latches	Lubricate	SAE 100 Oil or SAE Lubricant
Roller Bearing	Lubricate	Refer to Diagram, Multiple EP
Tire Treads	Lubricate	Consult Super Lube
Power Winch	Check Fluid Level	EP 46000 Hydraulic Oil
Spring Drive		API DLS
6 MONTH OR 250 HOURS MAINTENANCE (QUALIFIED SERVICE TECHNICIAN)		
Chassis	Check	
Platform Connections	Check Smooth Operation & Spacing	
Fuel Filter	Replace Filter	Refer to Manual
Roller Bearing (Tire) & Pinion	Lubricate	Refer to Diagram, Deep Lubricant
Engine RPM	Check Engine RPM	
Engine Oil Filter	Replace Oil Filter	Refer to Manual, SAE 100
Hydraulic System Filter	Replace Filter	Refer to Manual, SAE 100
YEARLY OR 500 HOURS MAINTENANCE (QUALIFIED SERVICE TECHNICIAN)		
Hydraulic Oil Reservoir	Check Fluid Level	Refer to Manual, SAE 100
Power Winch	Check Fluid Level	EP 46000 Hydraulic Oil
Spring Drive	Check Fluid Level	API DLS
Power Winch	Check Fluid Level	EP 46000 Hydraulic Oil
Spring Drive	Check Fluid Level	API DLS



WARNING: Failure to perform Preventive Maintenance at the intervals outlined in the manufacturer's maintenance manual may result in a unit being operated with a defect. This could result in the injury or death of the operator.

ANSI A92.5 – 1992 8.4 Problems or Malfunctions. Any problems or malfunctions that affect the safety of operations shall be repaired prior to the use of the aerial platform.

PROTECT YOURSELF

Wear all the protective clothing and personal safety devices issued to you or called for by job conditions.

You and other workers may need:

- Safety harnesses and lanyards connected to an anchorage point
- Safety shoes
- Safety glasses, goggles, or face shield
- Heavy gloves
- Hearing protection
- Wet weather gear
- Respirator or filter mask
- Insulated hard hats
- Insulated gloves and sleeves
- Insulated shields, covers and mats
- Insulated tools
- Cotton clothing
- First aid kit



Be sure you (and any others on the platform) are wearing your personal fall-protection device (if required) and it is properly attached to the appropriate lanyard attachment point.

Never attach a lanyard to the railing unless it is specifically designed as an attachment point.

Attach your lanyard so that if you fall, your free fall will be limited to a maximum of 4 feet.

If your attachment point will not allow this, then use a shorter lanyard.

NEVER attach your lanyard to an adjacent structure!

Never rest against an adjacent structure to stabilize the platform

Wear all other personal protective equipment (PPE) required for the job.

KNOW YOUR EQUIPMENT

Use all Available Protective and Safety Devices



Your platform may be equipped with:

- Chain, gate or bar closures
- Fall protection device
- Stabilizers or outriggers
- Barricade or barrier kit
- Warning lights
- Emergency controls
- Insulated shields, cover, mats
- Insulated liner
- Grounding equipment
- Ground controls
- Control lever lock
- Audible and visual alarms

Use them! Never remove, disconnect or bypass any safety device.



Keep all protective and safety device in place and in proper working order. Make certain all guards, railings, covers and safety signs are installed on the aerial platform as required by the manufacturer.

Know which devices are required on your machine.

Be familiar with how they work.

Never remove or modify any of them.

WARNING: All operators must be trained and have received proper instructions before operating aerial platforms. For your safety, warning notices are placed on the platform and in the manufacturer's manual. Failure to obey warnings can cause injury or death.

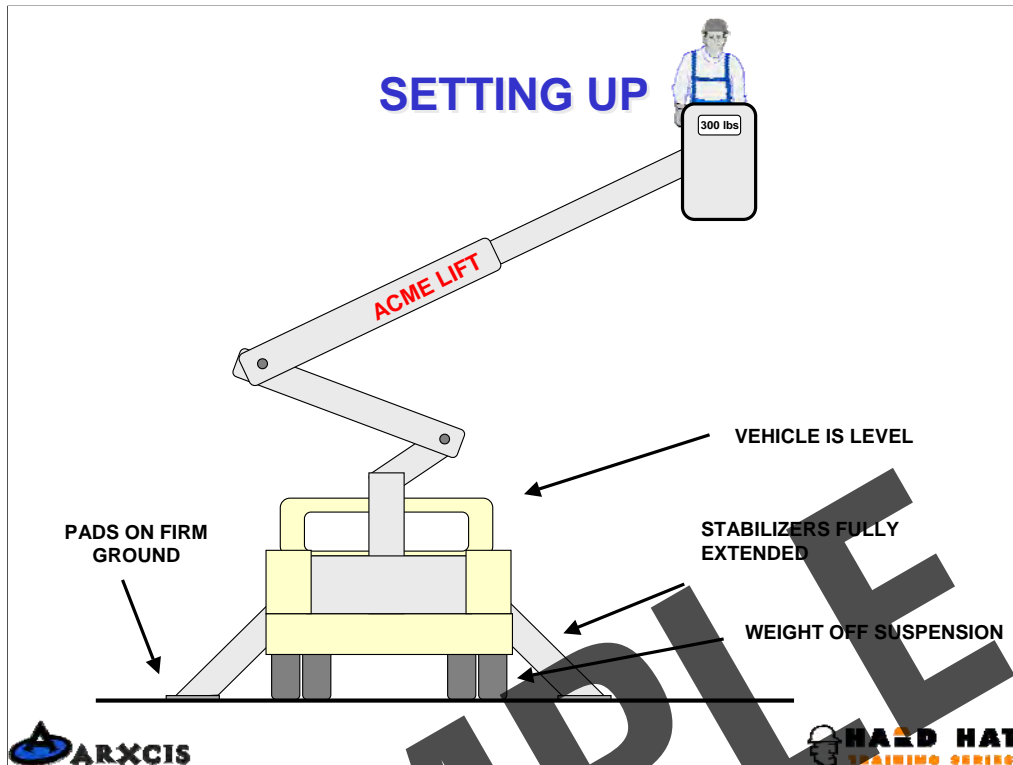

1. Point out each of the areas that need to be taken into consideration when setting up the bucket truck.
2. When the stabilizers are fully extended the tires may not be off the ground but the weight of the truck will primarily be on the stabilizers.

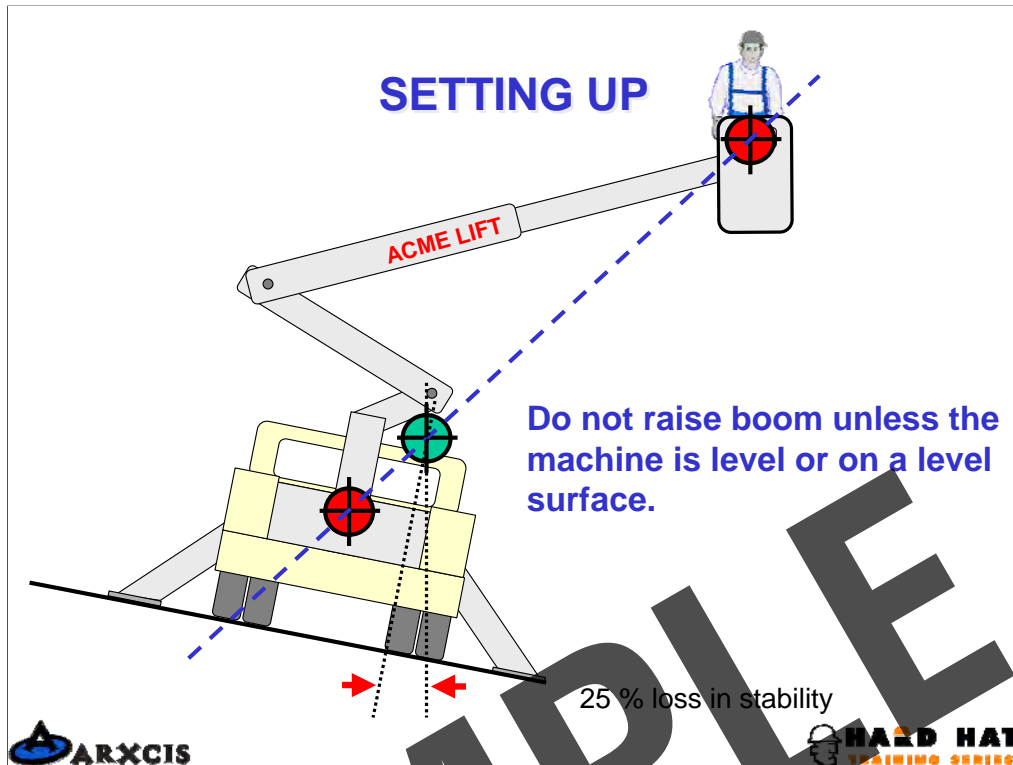

1. Many utilities will try and set up on the side of the road so as not to block traffic. This is fine, but do not do this if the ground is not level or you are unable to level the vehicle.
2. In the example above, the distance between the center of gravity of the truck and the tipping point (outrigger pad) has been reduced, thus reducing the safe working load.
3. Even though it appears that it would still be within safe working parameters, if you add a few dynamic conditions (wind, erratic booming or soft soil), it greatly increases the possibility of a tip over.

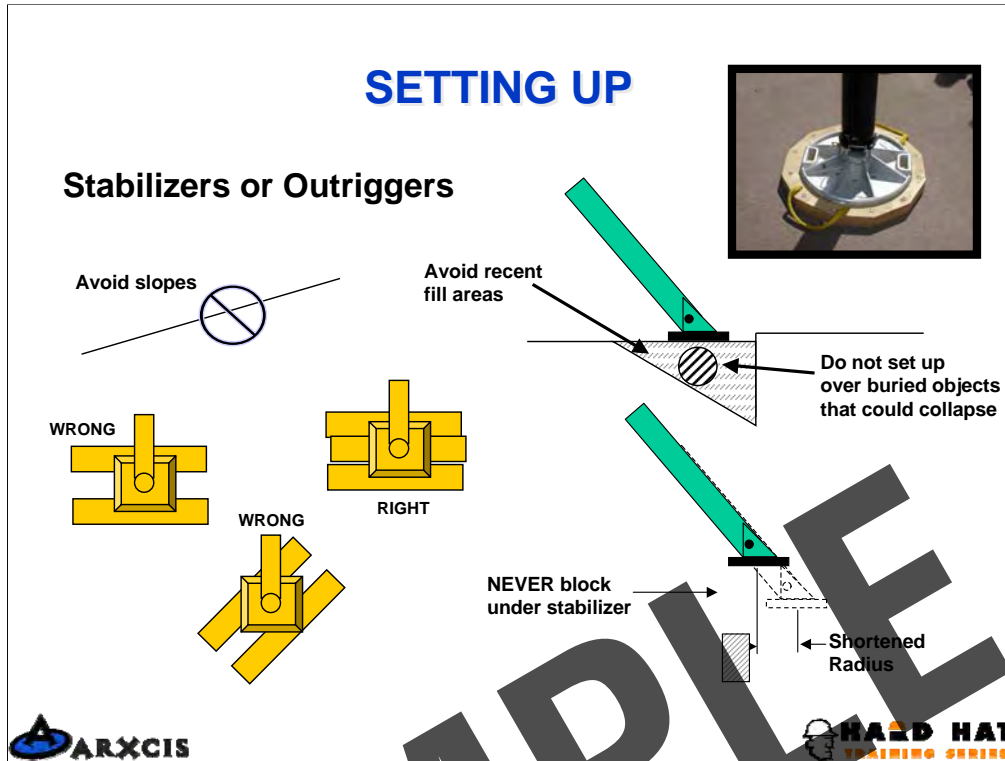

1. The first consideration is the quality of the surface the boom truck will be set up on.
2. Soils along the foundation of buildings are often poorly compacted and may contain drain pipe and other voids. Setting up in these areas should be avoided when possible and additional floats used when not.
3. Floats of at least 24" X 24" should be used under each stabilizer pad regardless of the type of surface being set up on. The use of these floats will reduce the pounds per square inch loading on the surface which will help prevent the stabilizer from sinking.
4. Blocking under the A-frame type of stabilizer which prevents the stabilizer from fully deploying should be avoided. Doing so will shorten the distance from the stabilizer pad to the center of rotation which results in a loss of leverage for the boom truck and makes it more likely to tipping over.
5. Always extend both outriggers. Not doing so can result in the boom truck tipping over.

ELECTROCUTION HAZARDS

Electric Shock - Direct Contact With Overhead Line

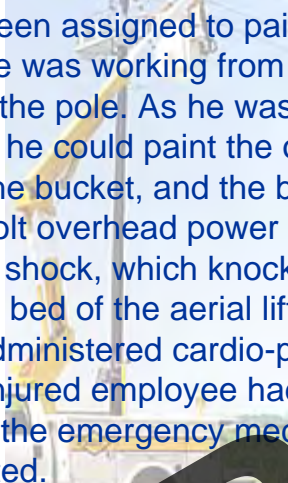

An employee had been assigned to paint a metal utility pole with a spray gun. He was working from an aerial lift and had painted one side of the pole. As he was rotating the bucket of the aerial lift so that he could paint the other side of the pole, he leaned back in the bucket, and the back of his neck contacted a 7960-volt overhead power line. The employee received an electric shock, which knocked him out of the bucket and onto the bed of the aerial lift truck. Two co-workers broke his fall and administered cardio-pulmonary resuscitation. Unfortunately, the injured employee had no heartbeat and was not breathing when the emergency medical team arrived. He had been electrocuted.



This is one of over 3,000 electrocutions that took place in the workplace. They occurred over a 10 year period and are found on the OSHA website. Nearly 20% of these were workers performing their jobs on aerial platforms near high voltage electrical lines. Some of these people were working on the lines themselves in an insulated aerial lift. Others were painters, construction or tree trimmers working near lines. All of these deaths could have been prevented with better training and job planning. If you are working near high voltage electrical lines, you better know what you're doing!

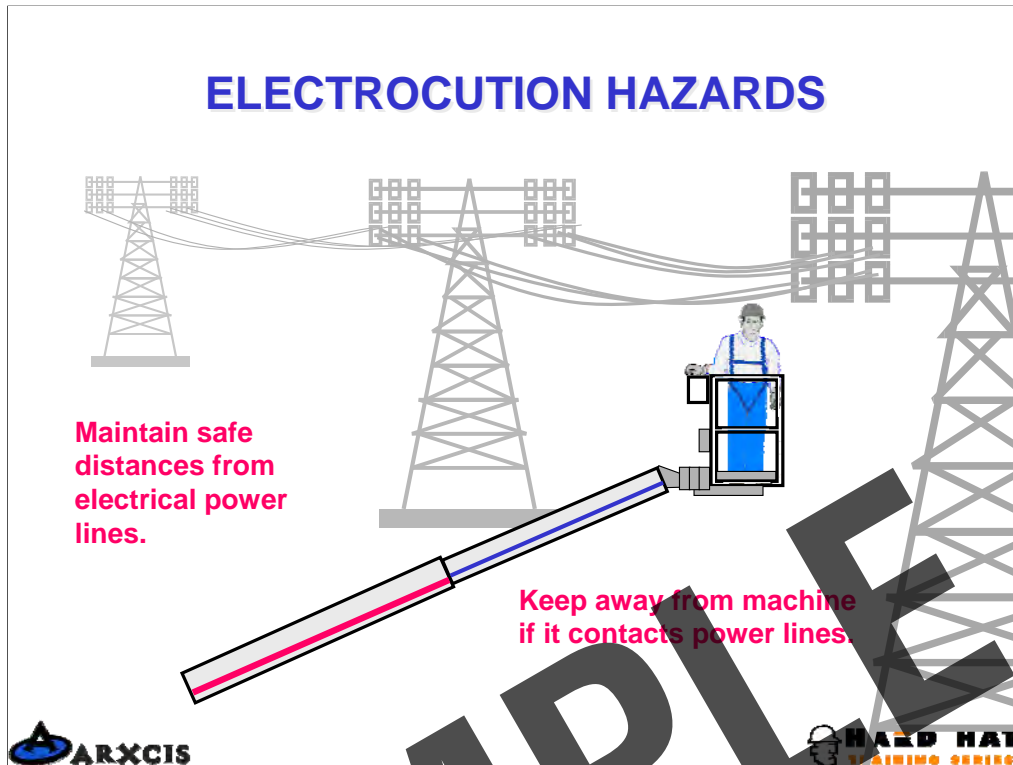

The number one cause of injuries or fatalities involving aerial platforms is contact with electrical wires.

Stay away from live power lines.

If you must work near live power lines, make sure they are de-energized.

Insulated booms are not a fail-safe measure from electrocution.

Booms that are insulated must be dielectric tested often. Note: Dirty booms or contaminated hydraulic fluid can be a conductor of electricity.

ELECTROCUTION HAZARDS

Never operate during an electrical storm.

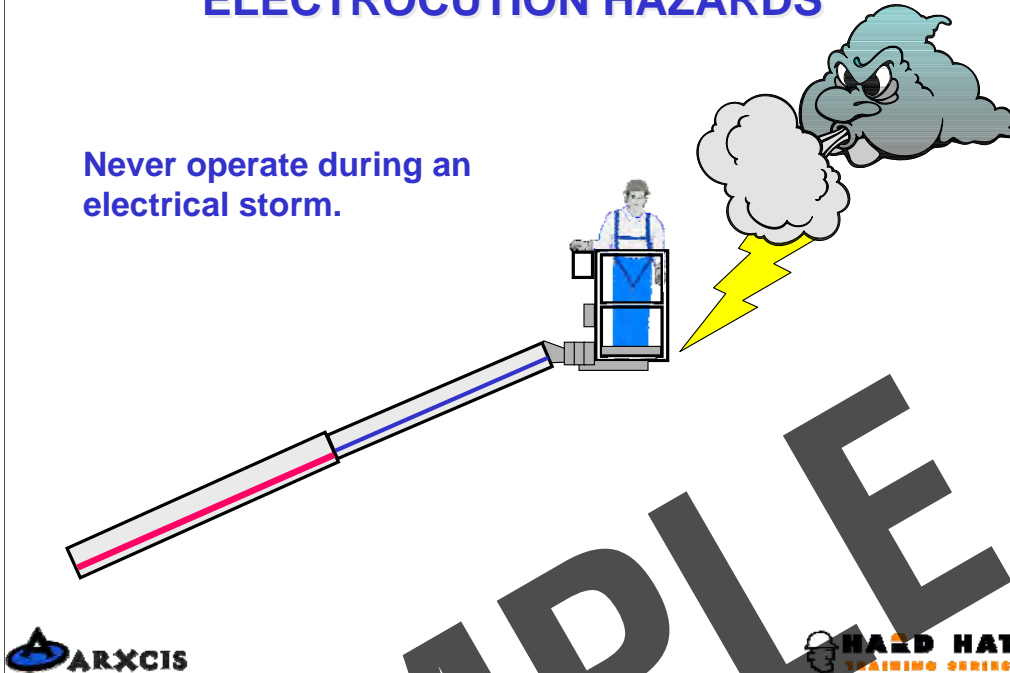

Never operate the lift during electrical storms.

SAMPLE

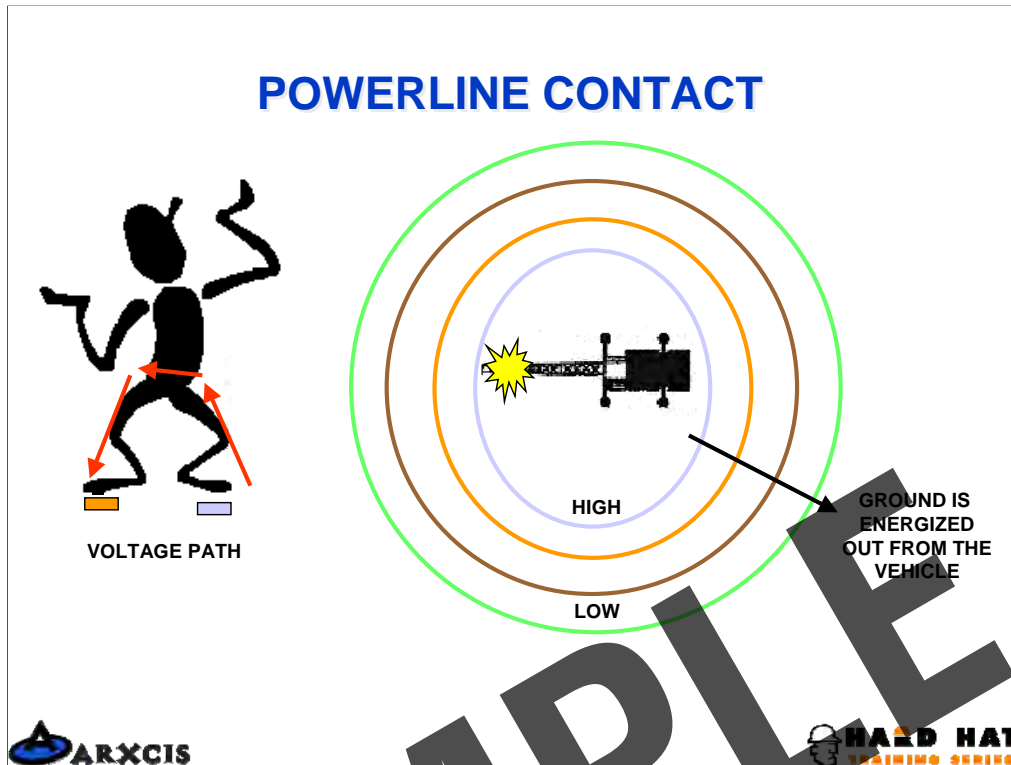

If you make contact with a power line and you are aware of it, then there is good news and bad news. The good news is you are still alive. The bad news is, of course, you are touching a live electrical wire which could be fatal to you and anyone nearby.

If your hands are still on the controls, then use the controls to back off the line.

If you let go of the controls, **do not touch them.** They could be energized. Call for help and warn everyone to stay away from the ground surrounding the lift.

Do not allow anyone to try to work the ground controls to free you. Not only could the ground around the machine be energized, but anyone touching the machine could be electrocuted.

Stay on the machine if possible, until help arrives and the lines are turned off.

Do not assume that your boom is insulated.

If you see someone in an aerial lift that has contacted an electrical line and is unconscious, do not try to be a hero by attempting to save them before the electric lines are shut off! Many that have tried become a victim also.

TIP-OVER HAZARDS

Do not raise boom in strong or gusty winds.

Check operator's manual for specific wind speed limits.

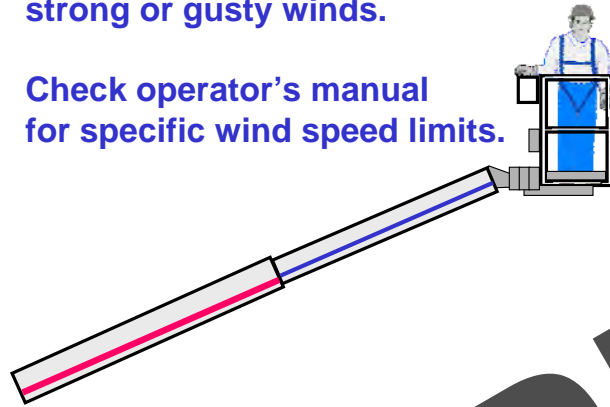

Do not raise boom in strong or gusty winds.
Check operator's manual for specific wind speed limits.

SAMPLE

TIP-OVER HAZARDS

Do not place ladders or scaffolds in platform or against any part of the machine.

While elevated in an aerial platform, do not push or pull any object outside of the platform.

Check the operator's manual for maximum side forces.

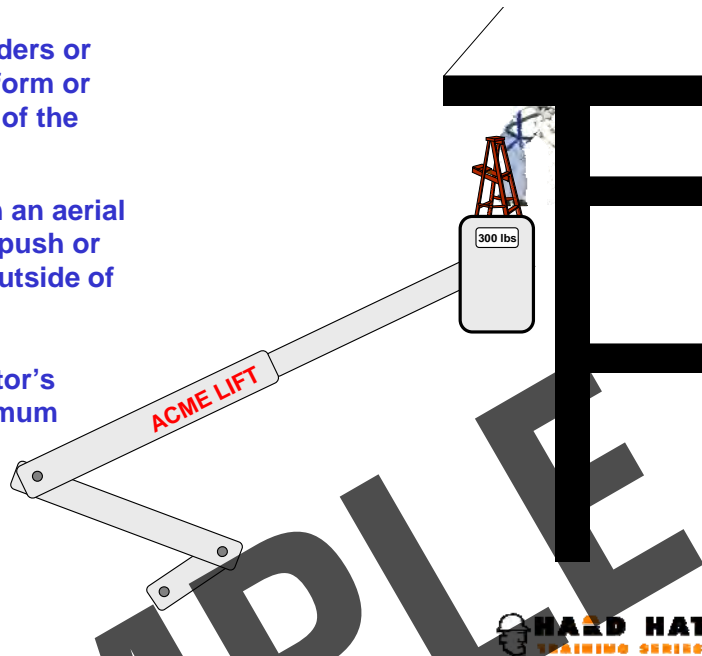

Never climb on the railing or side of the bucket to increase your reach.

Never place ladders or scaffolds in the platform or against any part of the machine.

SAMPLE

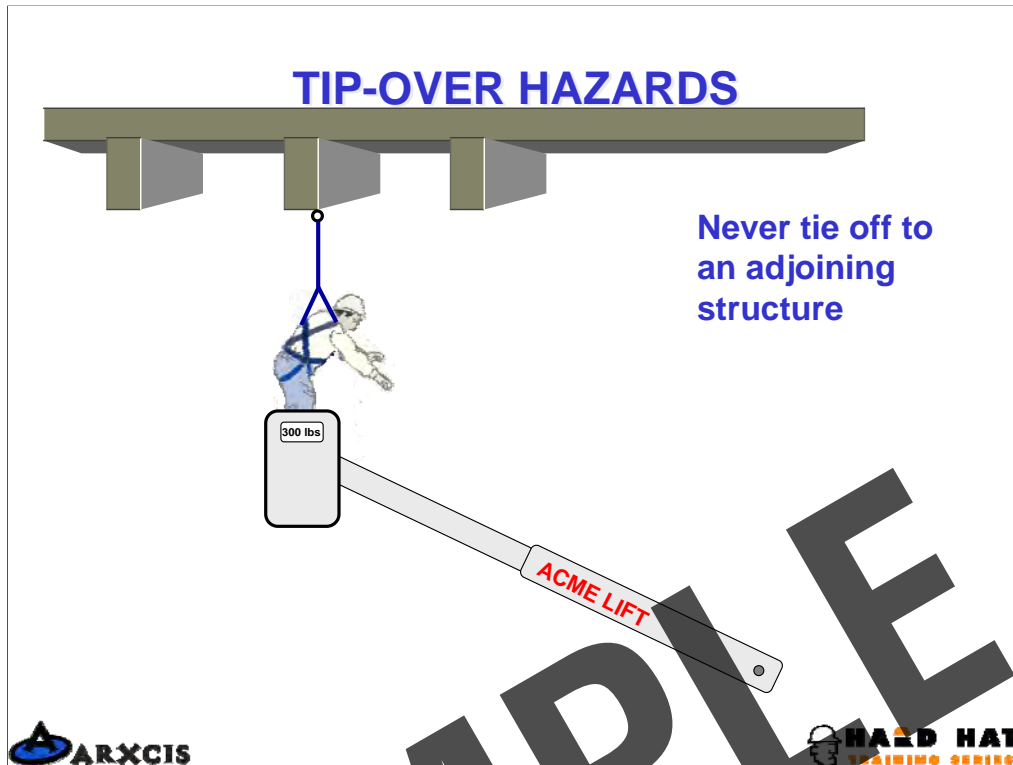

1910.67(c)(2)(iii)

Belting off to an adjacent pole, structure, or equipment while working from an aerial lift shall not be permitted.

Always tie off to an approved connection point.

TIP-OVER HAZARDS

Do not place or attach suspended loads to any part of the machine.

Do not use the machine for crane purposes.

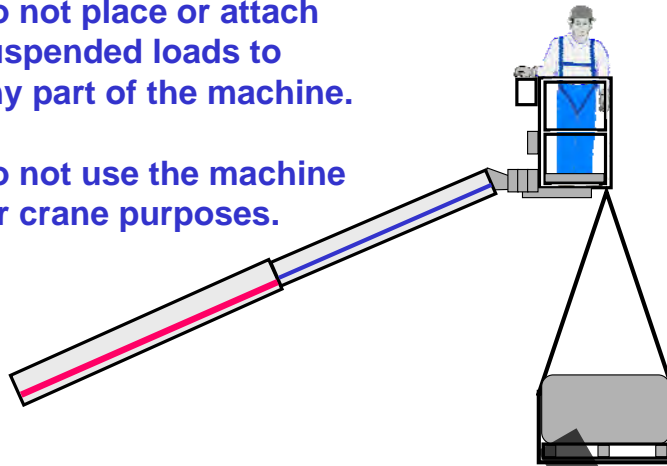

7.11.11 Misuse as a Crane. The aerial platform shall not be used as a crane.

SAMPLE

TIP-OVER HAZARDS

DON'T EXCEED THE MACHINE'S CAPACITY

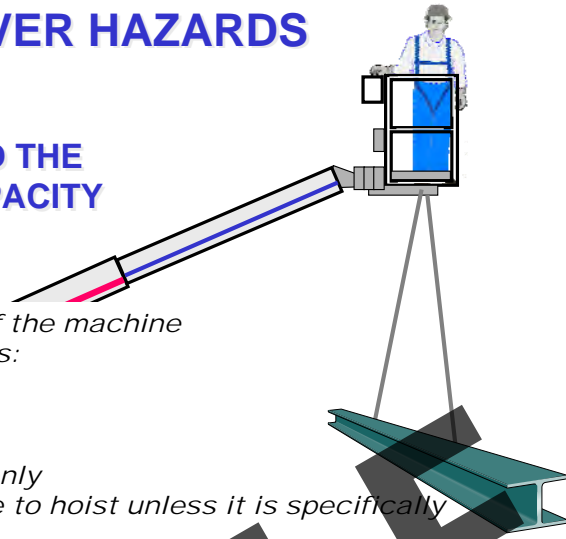

- Know the rated load of the machine
- Maximum load includes:
 - Personnel
 - Materials
 - Tools
- Distribute the load evenly
- Never use the machine to hoist unless it is specifically designed to do so.
- If the machine is designed to hoist, refer to the load chart and operator's manual for the capacity of the machine. Do not exceed.



The machine's safe working load must be visible to the operator and never exceeded. This includes any materials or tools that might be in the platform with the operator. Do not use the lift to hoist a load unless it is designed for that purpose.

8.10.7 Capacity Limitations. Rated capacities shall not be exceeded when loads are transferred to the platform at any height.

8.10.6 Entanglement. Care shall be taken to prevent rope, electric cords, and hoses, etc., from becoming entangled in the aerial platform.

FALL HAZARDS



Occupants of aerial platforms must wear a safety belt or harness in accordance with government regulations.



The number one cause of occupants being thrown from the machine is being hit by another vehicle. For this reason, you must always wear a harness and lanyard and be connected so that if you are thrown out, your free fall will not exceed 4 feet.

Never tie off to an adjacent structure when working from an aerial platform.

Never use ladders, planks, steps or other devices to provide additional reach or gain greater height.

Do not lean over, sit or climb on the platform railing. Always keep both feet on the platform floor.

[1926.453\(b\)\(2\)\(v\)](#) *see note below

A body belt shall be worn and a lanyard attached to the boom or basket when working from an aerial lift.

*Note to paragraph (b)(2)(v): As of January 1, 1998, subpart M of this part (1926.502(d)) provides that body belts are not acceptable as part of a personal fall arrest system. The use of a body belt in a tethering system or in a restraint system is acceptable and is regulated under 1926.502(e).

FALL HAZARDS

Being hit by another vehicle is the number one cause of being thrown out of the bucket. Always wear fall protection and direct traffic away from work area.

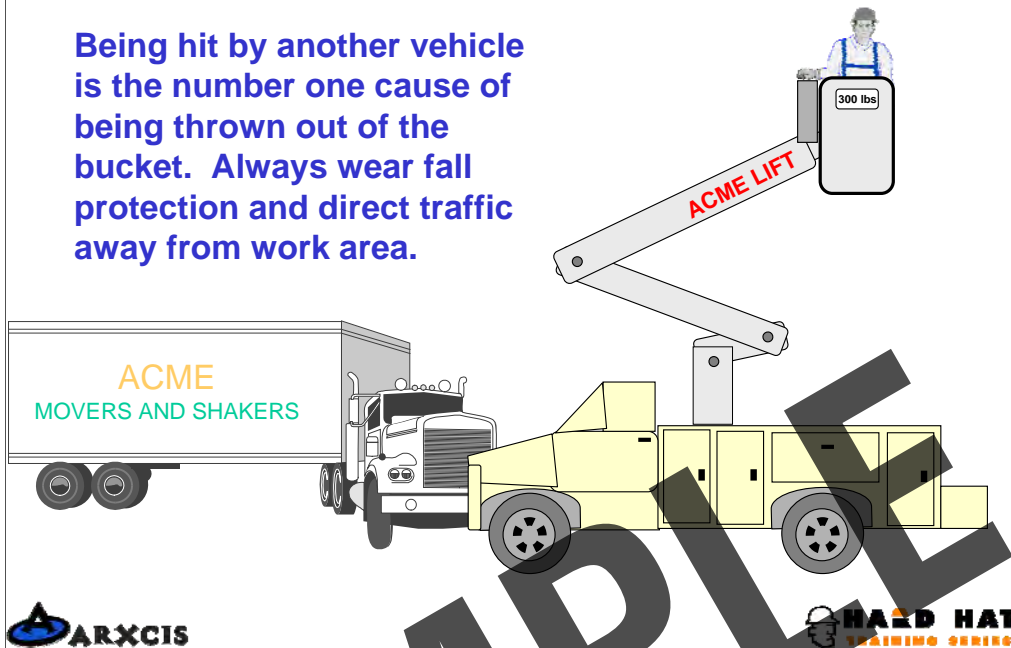

One of the reasons for wearing fall protection in an aerial lift is to prevent one from being ejected if another vehicle were to hit the lift.

Use the vehicle barrier kit.

Make sure you understand the rules covering traffic at your jobsite. Know what all signs, flags and markings mean. Know how to use lights, turn signals, flashers, and horns.

FALL HAZARDS

Do not climb down the boom from a raised platform.

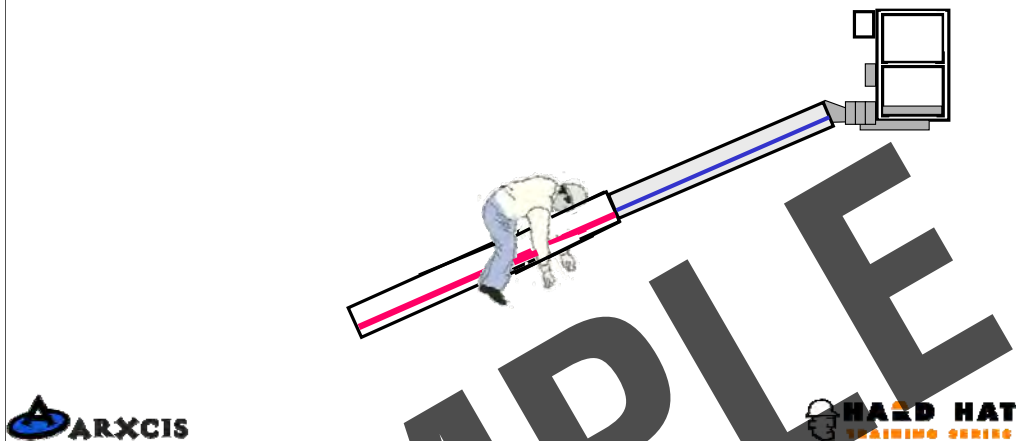

Always check the ground controls before operation of the lift. Make sure that the emergency controls in the bucket work. Never attempt to climb down the boom. Call or signal for help.

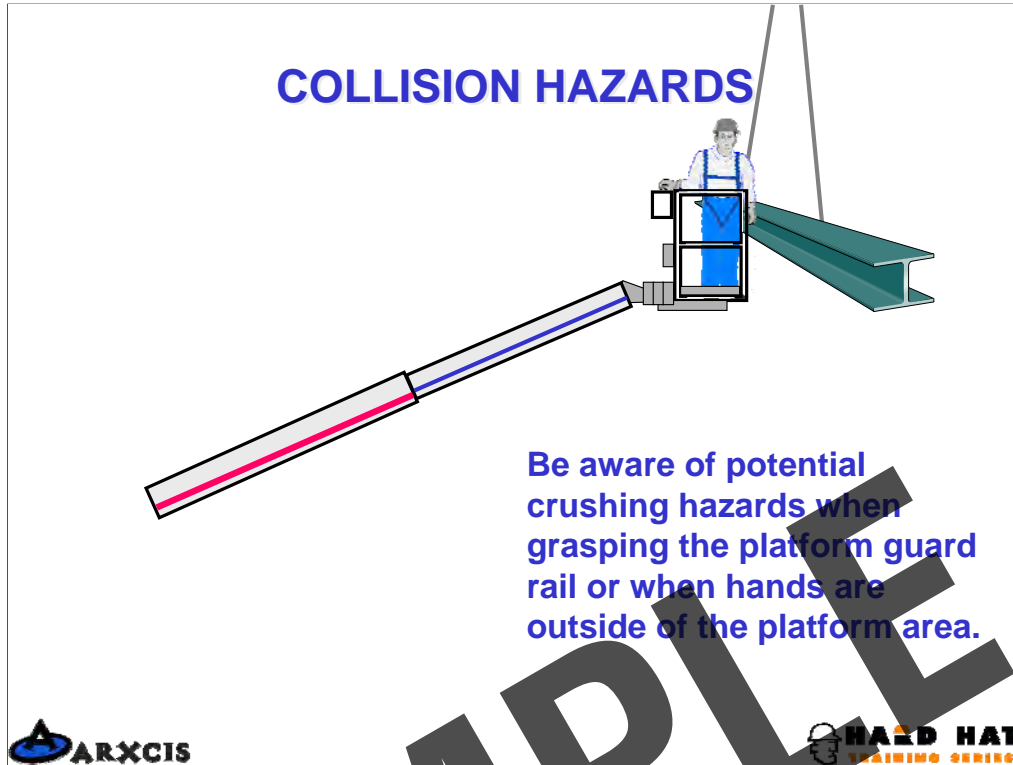

7.11.14 Elevated Driving Requirements. Before and during driving while the platform is elevated, the operator shall:

- (1) Maintain a clear view of the path of travel
- (2) Maintain a safe distance from obstacles, debris, drop-offs, holes, depressions, ramps, and other hazards to ensure safe elevated travel
- (3) Maintain a safe distance from overhead obstacles.

COLLISION HAZARDS

Check work area for overhead obstructions. Be aware of crushing hazards. Always look in the direction of the platform movement.

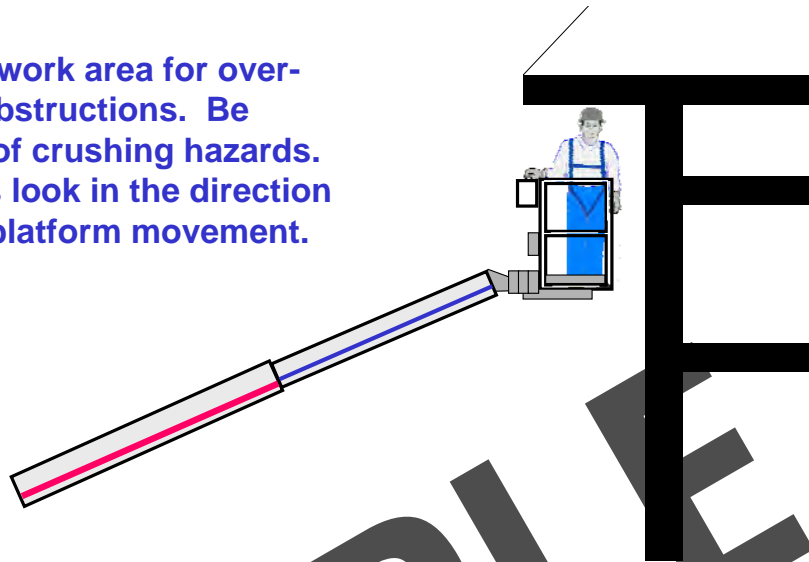

WARNING: Always check clearances above, below and on all sides before raising, lowering or rotating the platform. If applicable, also check turntable and counterweight clearances. Failure to do so could cause severe injury or death to yourself and/or others.

On a boom type machine, do not use the drive to maneuver in close to an obstacle. Place your machine and then use the swing and boom functions to get in close. Never drive the base or platform into a stationary object.

7.11.14 Elevated Driving Requirements. Before and during driving while the platform is elevated, the operator shall:

- (1) Maintain a clear view of the path of travel
- (2) Maintain a safe distance from obstacles, debris, drop-offs, holes, depressions, ramps, and other hazards to ensure safe elevated travel
- (3) **Maintain a safe distance from overhead obstacles.**

COLLISION HAZARDS

Take special care when working in or around trees. Controls should be guarded so as to avoid inadvertent contact by limbs or branches.

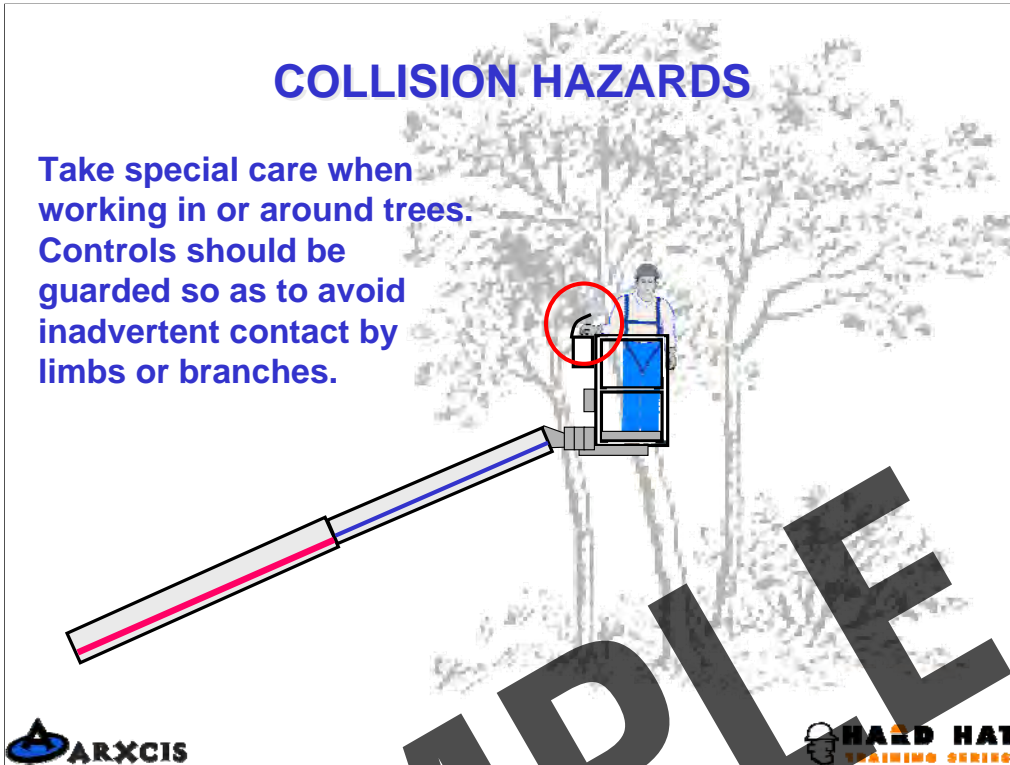

Take special care when working in or around trees. Check for concealed power lines. Controls should be guarded so as to avoid inadvertent contact by limbs or branches. If you are trimming branches, make sure the fall path of the branch is not toward the boom or any other part of the lift.

COLLISION HAZARDS

Do not lower the boom unless the area below is clear of personnel and obstructions.

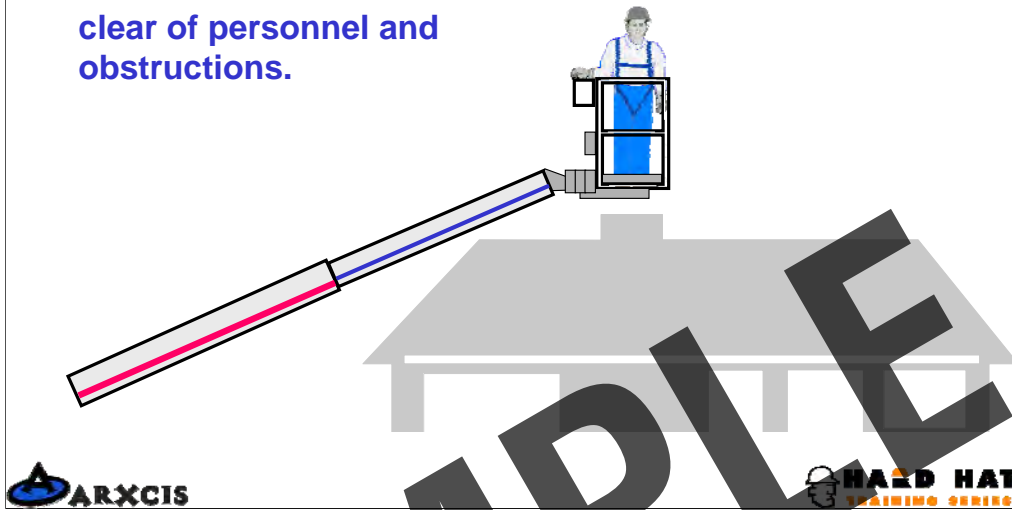

Always check below before you lower the platform or bucket. Check path of boom.

SAMPLE