



**HARD HAT**

**TRAINING SERIES**

BY: ARXCIS, INC.



**VEHICLE MOUNTED  
AERIAL PLATFORM  
OPERATOR  
SAFETY TRAINING**

## **STUDENT MANUAL**

SAMPLE

This student manual is intended to be used with the *Vehicle Mounted Aerial Platform Training Slides* (VM 04.10). It, along with the presentation is designed to point out basic safety situations which may be encountered during the normal operation and maintenance of your equipment and to suggest possible ways of dealing with these situations. **It is not a substitute for the manufacturer's operation and maintenance manual(s).**

REMEMBER: The operator and maintenance manual must be on the machine at all times and everyone who operates the machine must read and understand it prior to use.

If you do not have the manufacturer's operation and maintenance manual(s) for your particular machine, get a replacement manual from your employer, equipment dealer, or from the manufacturer.

# Introduction

## Accident Profile

**Scottsdale, Ariz.**— A garbage truck sideswiped a boom lift aerial work platform while a worker was repairing a traffic signal. The collision threw the man from the personnel basket and killed him. When the operator fell from the basket, he hit his head on the bottom of the platform several times. According to reports, orange cones were in place around the intersection where the accident occurred.



This was not a freak accident. In fact, it is fairly common. Although the worker was in fact wearing a safety harness and was tied off to the machine, his lanyard was too long or tied off too high. The impact of the truck hitting the machine caused the boom to flex, ejecting the worker out of the machine, swinging him underneath the platform where the boom continued to bounce causing his head to hit the underside multiple times, resulting in severe head trauma. What could have prevented this accident?

## Why Aerial Lift Operator Safety Training?

1. Training can reduce the risk of accidents and injuries to you and those you work with.
2. Training can also reduce operating cost of your company by avoiding damage to property and product.
3. The Federal Occupational Safety and Health Act, OSHA, requires all operators to be trained and authorized to operate an aerial lift.



# Other Accidents

## An Assortment of Aerial Platform Accidents

### Electric Shock - Direct Contact With Overhead Line

A power line worker was working from an aerial lift, stringing a new neutral conductor. He was not wearing electrical protective equipment. He contacted a 4800-volt overhead power line and was electrocuted.

### Electric Shock - Direct Contact With Overhead Line

An employee had been assigned to paint a metal utility pole with a spray gun. He was working from an aerial lift and had painted one side of the pole. As he was rotating the bucket of the aerial lift so that he could paint the other side of the pole, he leaned back in the bucket, and the back of his neck contacted a 7960-volt overhead power line. The employee received an electric shock, which knocked out of the bucket and into the bed of the aerial lift truck. Two coworkers broke his fall and administered cardio-pulmonary resuscitation. Unfortunately, the injured employee had no heartbeat and was not breathing when the emergency medical team arrived. He had been electrocuted.

Port Huron, Mich. – A city worker was killed when a tractor-trailer hit the bucket truck he was in. The worker was repairing a traffic light in the right lane. The tractor-trailer traveling by in the left lane hit the boom as it was being lowered. A preliminary investigation indicated that the worker was not wearing fall protection equipment and that no traffic directional signals had been used.

# TRAINING RESPONSIBILITIES

Only trained and authorized personnel must be permitted to operate the aerial platform. Before using it, the operator must:

- (a) Read and understand the manufacturer's operating instructions and safety rules, and be trained by a qualified person on the contents of the manufacturer's instructions and safety rules.
- (b) Read and understand all decals, warnings, and instructions on the work platform.
- (c) On a daily basis, before the aerial platform is used, it must be given a thorough inspection.

**The following standard was taken directly out of the ANSI/SIA 92.5 – 1990 for Vehicle-Mounted Elevating and Rotating Aerial Devices:**

## Training of Operators:

Each trainee shall be instructed in the safe and proper operation of the aerial device utilizing the manufacturer's operator's manual, the user's work instructions, and be familiar with all other applicable standards.

**The following standards were taken directly out of the ANSI/SIA 92.2 – 1992 for Boom-Supported Elevating Work Platforms:**

## Model training

The user shall be responsible for the operator being trained on the model of the aerial platform that he will be operating. Such training shall be in an area free of obstructions, under the direction of a qualified person for a time sufficient to determine that the trainee display proficiency in knowledge and actual operation of the aerial platform. Only properly trained and authorized personnel shall be permitted to operate the aerial platform.

## Before operation

Before authorizing an operator to operate an aerial platform, the user shall ensure that the operator has:

- a) Been instructed by a qualified person in the intended purpose and function of each control.
- b) Read and understood the manufacturer's operating instruction(s) and users safety rules, or been trained by a qualified person on the contents of the manufacturer's operating instruction(s) and users safety rules.
- c) Understood by reading or by having a qualified person explain all decals, warnings, and instructions displayed on the aerial platform.
- d) Determine that the purpose for which the aerial platform is to be used is within the scope of the intended applications defined by the manufacturer.
- e) Been provided with approved fall protection devices and other safety gear for all personnel in the platform.



# INSPECTION REQUIREMENTS

**Initial Inspection and Test.** Prior to initial use, all new or modified mobile units shall be inspected and tested to ensure compliance with the provisions of this standard.

**Frequent Inspection and Test.** The following tests and inspections shall be performed by the operator once daily, prior to first use:

- Operating controls for conditions interfering with proper operation
- Visual and audible safety devices for malfunction
- Hydraulic or pneumatic systems for observable deterioration or excessive leakage
- Fiberglass and other insulating components for visible damage or contamination
- Missing or illegible operational markings
- Electrical apparatus for malfunction, signs or excessive deterioration, dirt, and moisture accumulation

**Periodic Inspection and Test.** At one to twelve month intervals, depending on the severity for service and environment, the mobile unit should be inspected for the following:

- Structural members for deformation, cracks or corrosion
- Pins, bearings, shafts, gears, rollers, locking devices, chains, chain sprockets, wire rope, and sheaves for wear, cracks or distortion
- Hydraulic and pneumatic relief settings
- Hydraulic system for proper oil level
- Hydraulic and pneumatic fittings, hoses, and tubing for evidence of leakage, abnormal deformation, or excessive abrasion
- Compressors, pumps, motors and generators for loose fasteners, leaks, unusual noises or vibrations, loss of operating speed, and excessive heating
- Hydraulic and pneumatic valves for malfunctioning and visible cracks in the external valve housing, leaks, and sticking spools
- Hydraulic and pneumatic cylinders and holding valves for malfunction and visible damage
- Hydraulic and pneumatic filters for cleanliness and the presence of foreign material in the system
- Electrical systems and components for deterioration or wear including those not readily visible on a frequent inspection
- Performance test of all boom movements
- Condition and tightness of bolts and other fasteners
- Welds, as specified by the manufacturer
- Legible and proper markings of controls, ratings, and instructions

Perform any additional test as prescribed by the manufacturer.





# TYPES OF AERIAL PLATFORMS



Vehicle-Mounted Aerial Platforms come in all shapes and sizes. The main differences are in the type of boom it has and what it is primarily used for. Most can be divided into **straight** and **articulating** booms.

It is also important to know if the aerial platform that you will be using has an **insulated boom** to help prevent accidental shock if it contacts an overhead power line.

Some machines have been rated by the manufacturer for traveling while the boom is up for certain jobs that would require it. It is important to know your machine and be trained and authorized to operate it.



## Operator's Manual

It is the responsibility of the operator to read and understand the operator's manual and any manufacturer's manual(s) before operating the machine.

The operator's manual should be on the machine at all times and available to anyone who operates or does maintenance work on it.

## Operator's Manual

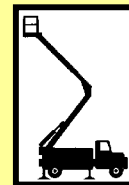

VMAP-689T

VEHICLE MOUNTED  
AERIAL PLATFORMS



# PRE-OPERATION INSPECTION

The machine is required to be inspected prior to each use. Each of the items on the right should be inspected and tested. Perform any additional tests required by the manufacturer.



- Decals legible and in place
- Engine fluids at correct levels
- Electrical components & wiring
- Hydraulic hoses, fitting, cylinders
- Fuel & hydraulic tanks
- Drive & turntable motors & drives
- Boom extension cables & wear pads
- Boom damage & dents
- Tires & wheels
- Engine & related components
- Limit switches, alarms, horns, beacons
- Nuts, bolts, & other fasteners
- Platform rail & entry gate
- Cracks in welds & structural components
- Compartment covers in place & latched
- Platform & ground control operations
- Auxiliary power function

## DECALS AND WARNING LABELS

The following information must be displayed on all aerial platforms in as permanent and as visible a manner as practical.

- Warnings, cautions, or restrictions for safe operation
- Make, model, serial number, and manufacturer's name and address
- Rated workload
- Maximum platform height
- Nominal voltage rating of batteries or rated voltage of AC line
- Statement concerning the need of the operator's familiarity with the work platform before it is used
- A statement of whether or not the aerial platform is electrically insulated

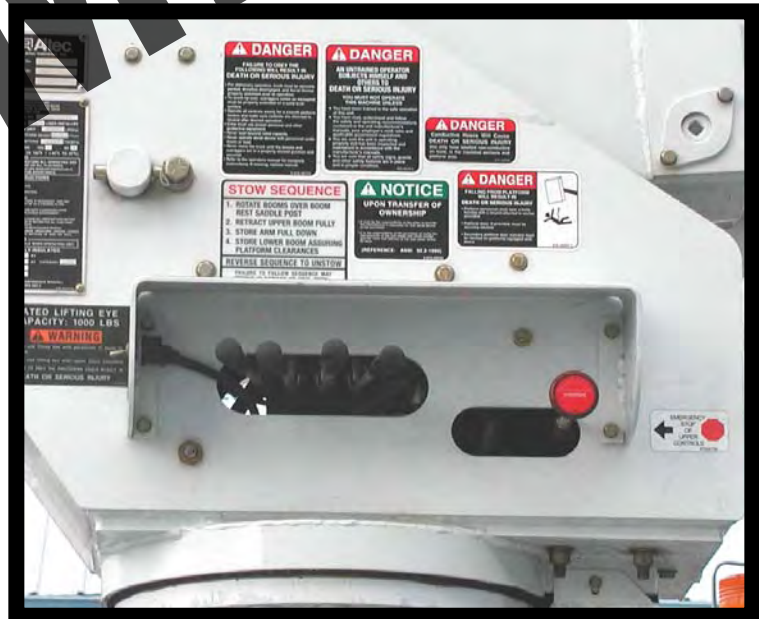

The user shall verify that all nameplates and markings are in place and are maintained in a legible condition.



# PRE-OPERATION INSPECTION

## CHASSIS & TURNTABLE

Check swing motor for loose bolts, damaged gears.

Check turntable base and chassis for objects left there.



## ELECTRICAL COMPONENTS

Check for damaged or loose electrical wiring and components.

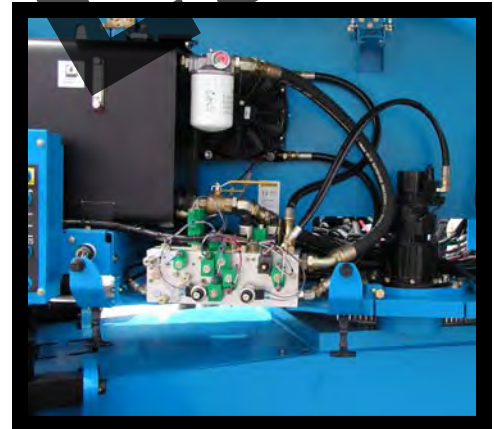

## LIFT CYLINDERS

Check the boom lift cylinders for hydraulic leaks and other damage.

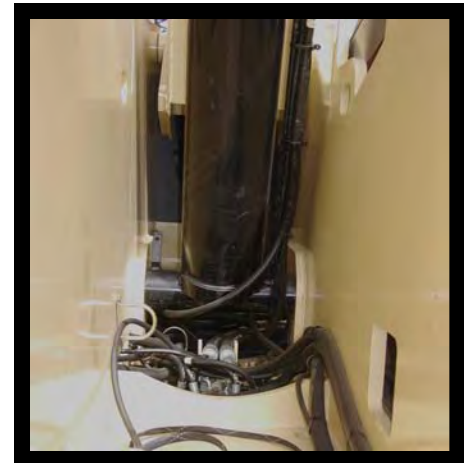

# PRE-OPERATION INSPECTION

## BUCKET CONTROLS

All directional controls must be marked for the direction they control and must be of the type which automatically returns to the “off” or neutral position when released.

Controls must be protected against inadvertent operation.



## BUCKET HINGES AND STRUCTURE

Check hinge for smooth operation.

Check hoses for chafing and other damage.



# PRE-OPERATION INSPECTION

## STABILIZERS

1. When the stabilizer is deployed it should extend smoothly.
2. Check for any dents or deformity in the box tubes.
3. The pads should not be bent up on the corners and should move freely on the hinge pin. Check to see that the pin keepers are present and that there is no excessive play in the pin area.
4. The upper hinge pin and bushing can be checked by lowering the stabilizer within a few inches of the ground and moving it back and forth. There will be some movement but excessive wear in this area needs to be repaired. Excessive wear will allow the vehicle to rock forward and aft when making a lift and cause further damage.
5. All welds associated with the structure need to be checked for cracks.
6. The attachment of the lift to the truck chassis needs to be checked. If bolted, check around the bolt heads and washer area to see if there is cracked paint or dirt which could indicate movement.
7. **Always use floats under the stabilizer pads.**

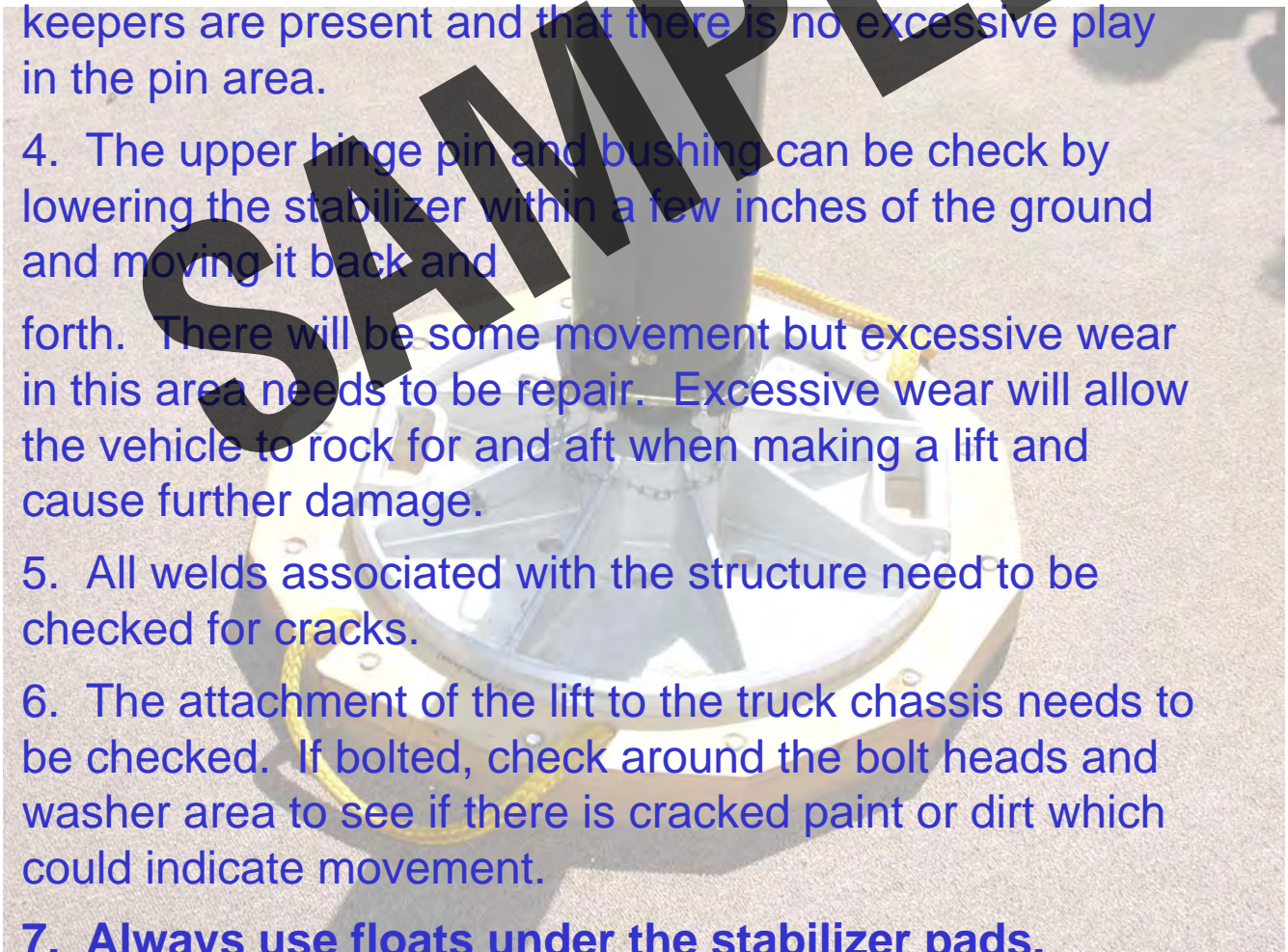

# PRE-OPERATION INSPECTION

## INSPECTING THE BOOM

The boom is like a tin can, very strong until it gets a dent on the side or underneath . Any dents should be checked with the specifications from the manufacturer and repaired if need be.

Electrically insulated booms must be dielectrically tested often. Many factors can contribute to a failure of this test including a dirty machine, contaminated hydraulic oil or cracks in the boom finish.

You must assume your machine is NOT electrically insulated unless it is specifically indicated on the machine rating plate.

Always keep your machine clean and free of excessive dirty and grease.

On the boom, look for leaks that may indicate leaky hydraulic cylinders.

Check slide pads for wear and adjust them when needed.

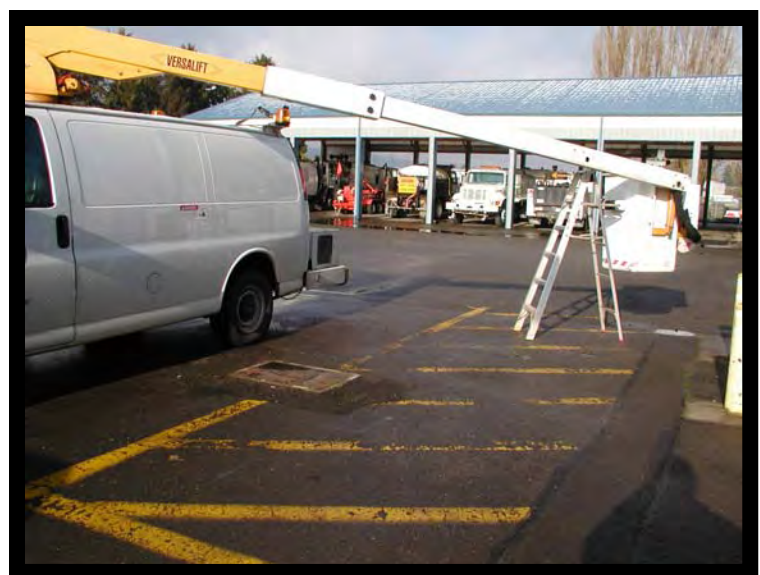

# PRE-OPERATION INSPECTION

## FUNCTIONAL TEST

**PRIOR TO PUTTING THE MACHINE INTO SERVICE,  
ENSURE ALL THE FUNCTIONS ARE PROPERLY WORKING.**

### At the ground controls:

- Activate Emergency Stop
- Activate each boom function
- Test auxiliary controls



### At the platform controls:

- Activate Emergency Stop
- Test horn
- Test foot switch
- Test boom and platform functions
- Test drive speed limits
- Test auxiliary controls



**Perform any additional test as prescribed by the manufacturer.**



# OPERATING THE AERIAL PLATFORM

Wear all the protective clothing and personal safety devices issued to you or called for by job conditions. You and other workers may need:

- Safety harnesses and lanyards connected to an anchorage point
- Hard hats
- Safety shoes
- Safety glasses, goggles, or face shield
- Heavy gloves
- Hearing protection
- Wet weather gear
- Respirator or filter mask

## Safe Operating Guidelines:

- Always look in the direction of boom travel.
- Assure the path of travel is firm and level.
- Maintain a safe distance from overhead obstacles.
- Limit speed according to conditions.
- Use caution when operating near slope, personnel, or other vehicles that could create a collision.
- Operator should maintain a firm footing on the platform.
- Maintain safe distances from power lines.
- Always connect your lanyard to an approved connection point.
- Use a lanyard that will keep your freefall to a maximum of 4 feet.



# SAFE OPERATION

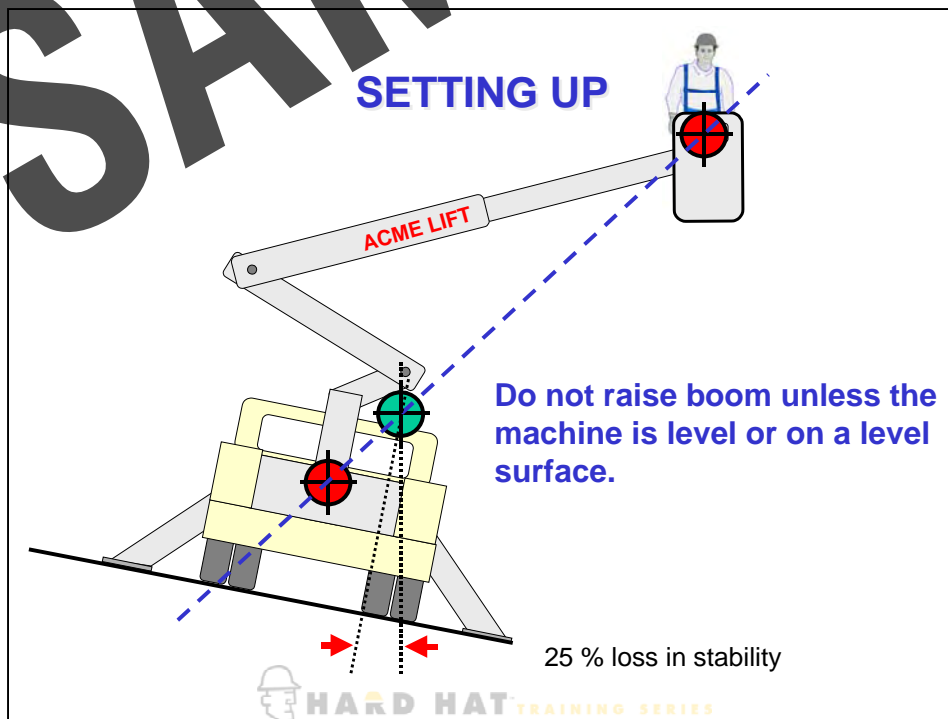
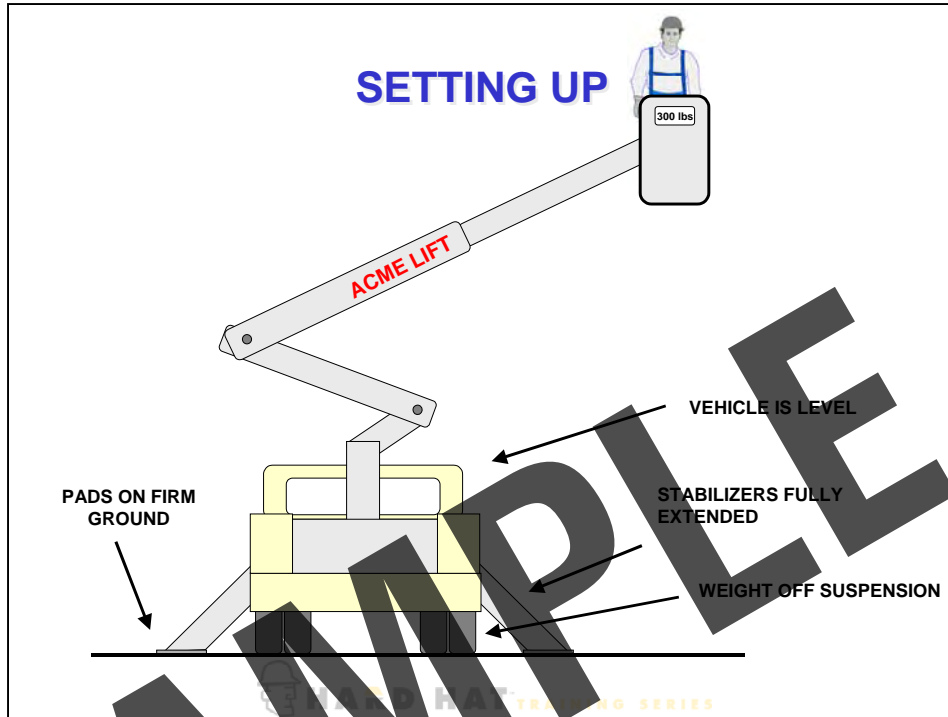

# SAFE OPERATION

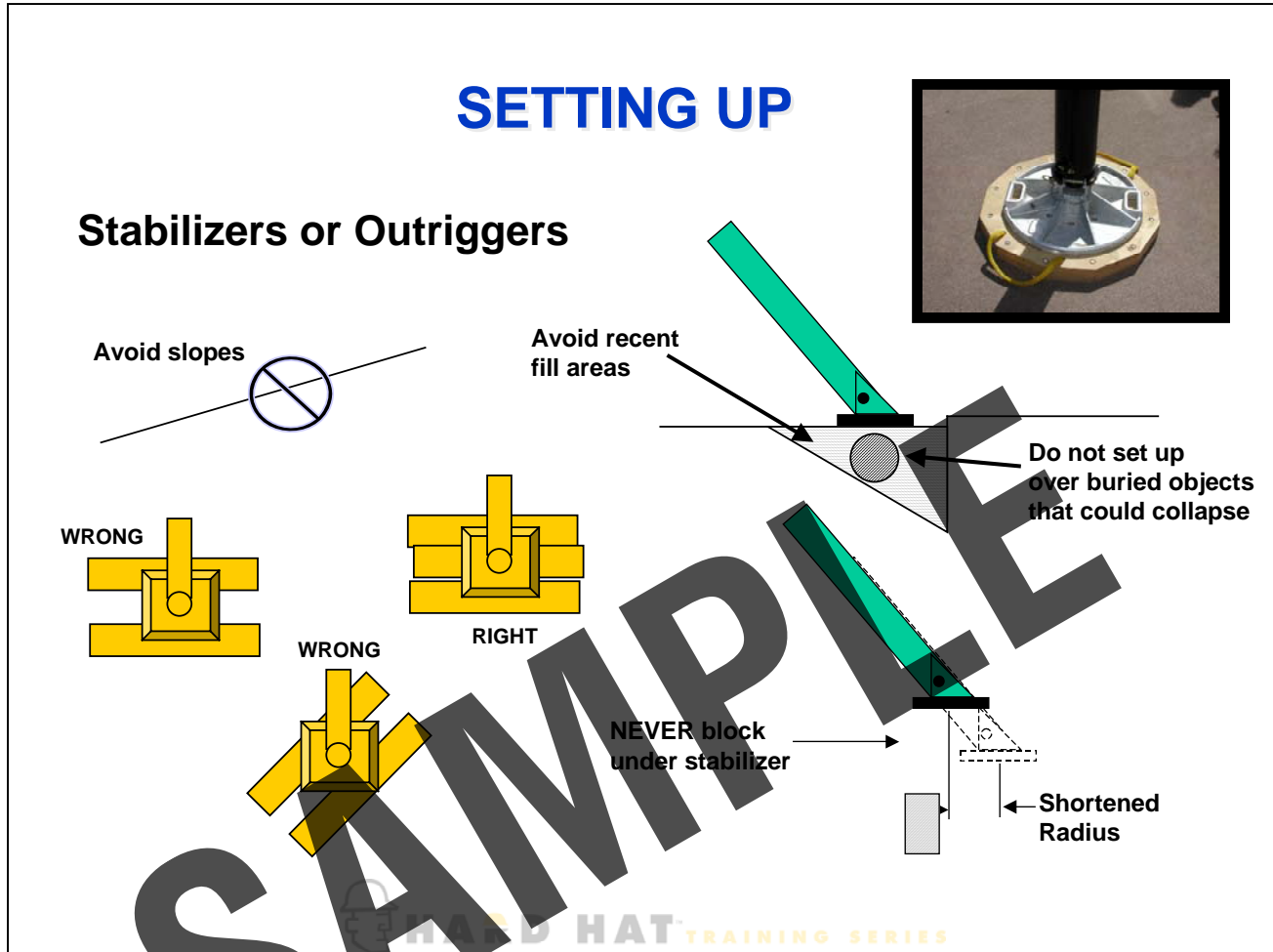

1. The first consideration is the quality of the surface the boom truck will be set up on.
2. Soils along the foundation of buildings are often poorly compacted and may contain drain pipe and other voids. Setting up in these areas should be avoid when possible and additional floats used when not.
3. Floats of at least 24" X 24" should be used under each stabilizer pad regardless of the type of surface being set up on. The use of these floats will reduce the pounds per square inch loading on the surface which will help prevent the stabilizer from sinking.
4. Blocking under the A-frame type of stabilizer which prevents the stabilizer from fully deploying should be avoid. Doing so will shorten the distance from the stabilizer pad to the center of rotation which results in a lose of leverage for the boom truck and makes it more likely to tipping over.
5. Always extend both outriggers. Not doing so can result in the boom truck tipping over.



# SAFE OPERATION

## ELECTROCUTION HAZARDS

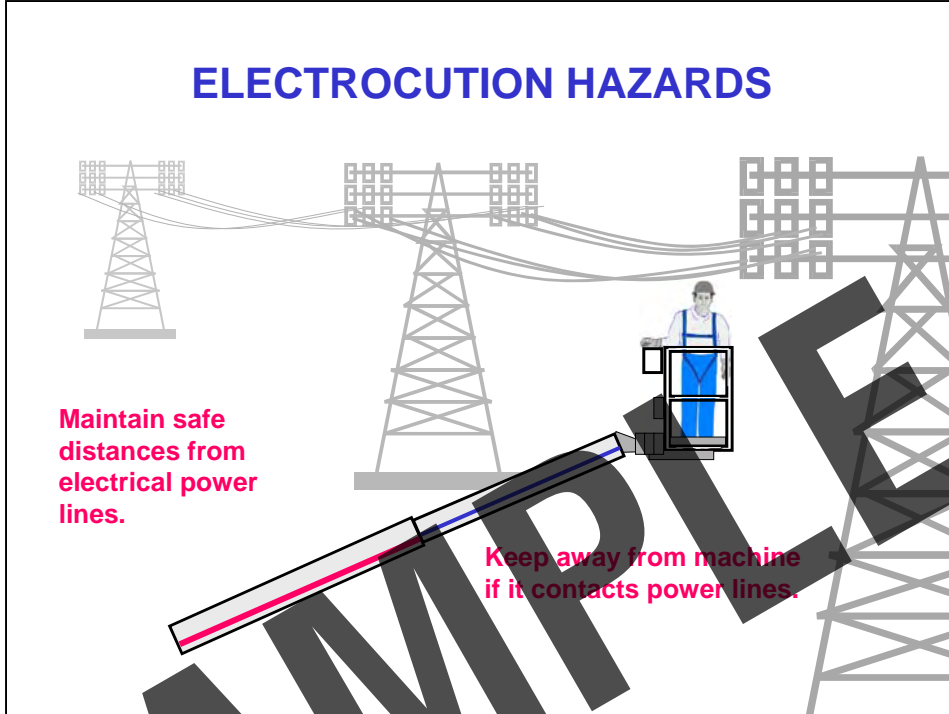

## POWERLINE CONTACT

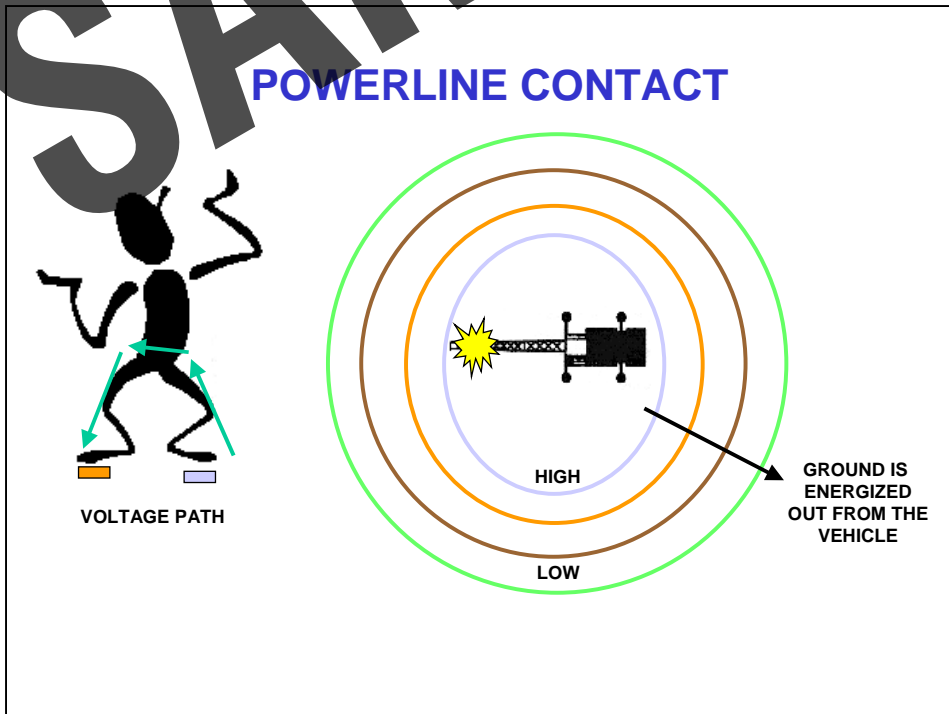

# SAFE OPERATION

## TIP-OVER HAZARDS

Do not raise boom in strong or gusty winds.

Check operator's manual for specific limits.

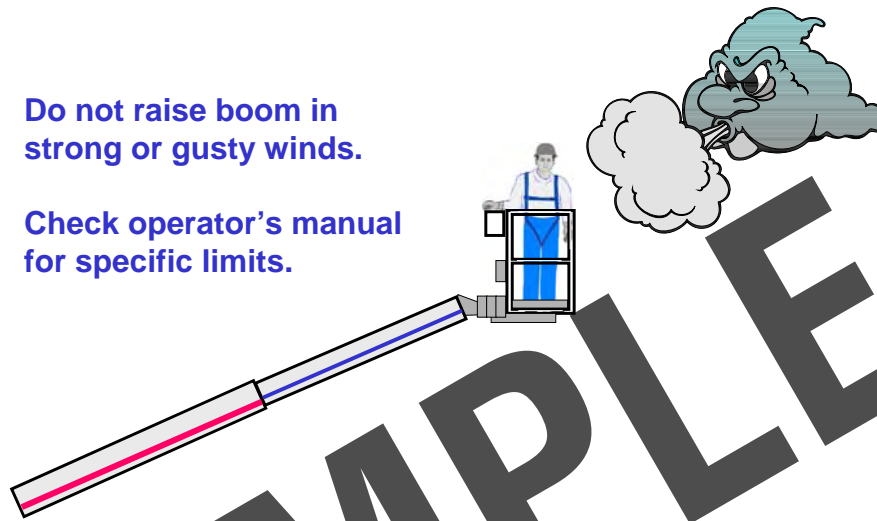

## TIP-OVER HAZARDS

Do not place or attach overhanging loads to any part of the machine.

Do not use the machine for crane purposes.

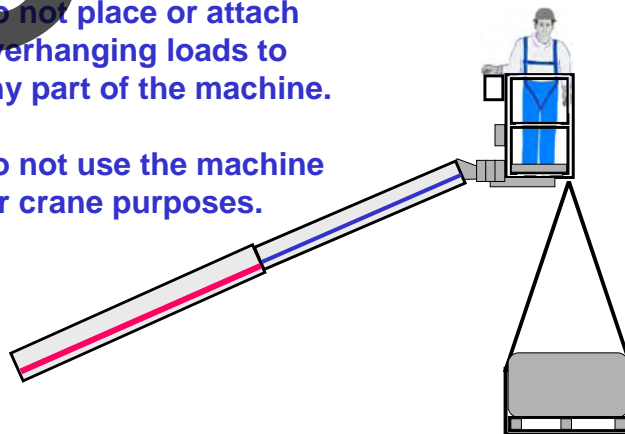

# SAFE OPERATION

## TIP-OVER HAZARDS

Do not place ladders or scaffolds in platform or against any part of the machine.

While elevated in an aerial platform, do not push or pull any object outside of the platform.

Check the operator's manual for maximum side forces.

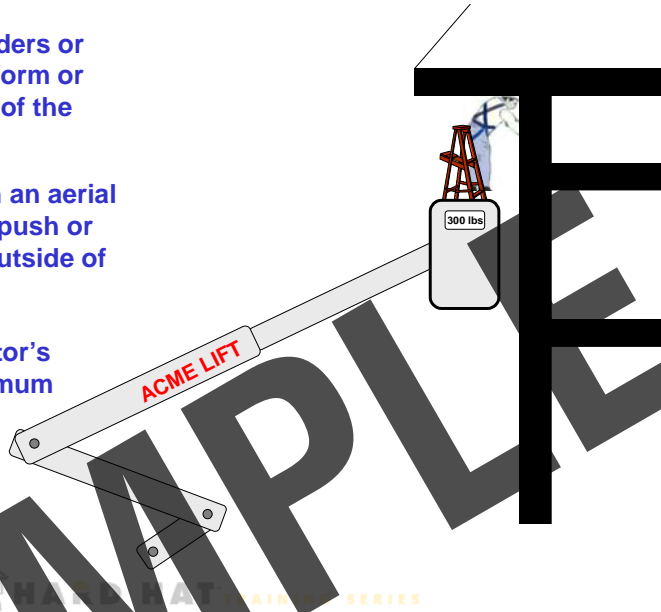

## TIP-OVER HAZARDS

Never tie off to an adjoining structure

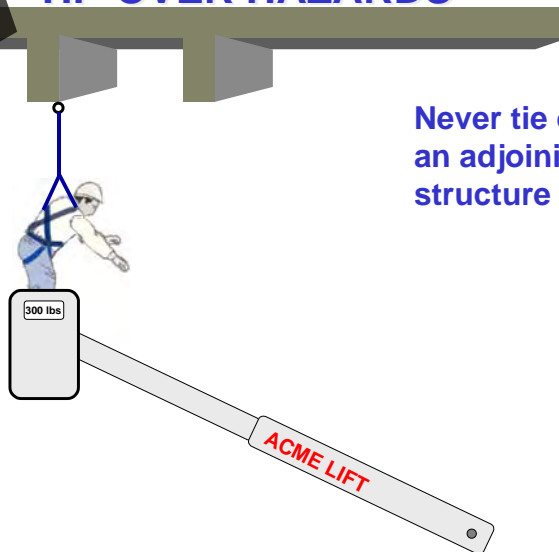

HARD HAT TRAINING SERIES



# SAFE OPERATION

## TIP-OVER HAZARDS

### DON'T EXCEED THE MACHINE'S CAPACITY

- Know the rated load of the machine
- Maximum load includes:
  - Personnel
  - Materials
  - Tools
- Distribute the load evenly
- Never use the machine to hoist unless it is specifically designed to do so.
- If the machine is designed to hoist, refer to the load chart and operator's manual for the capacity of the machine. Do not exceed.

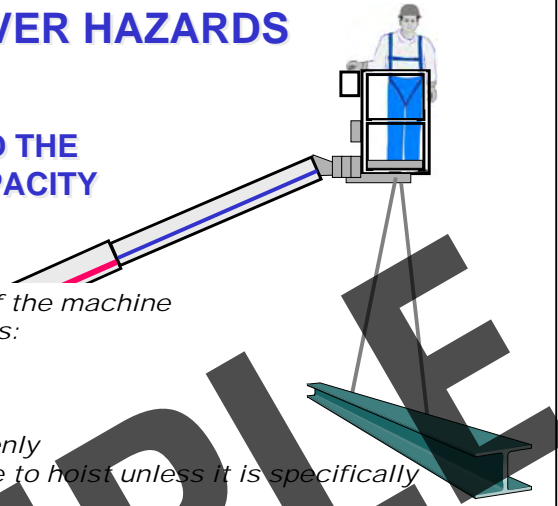

## FALL HAZARDS

Occupants must wear a safety belt or harness in accordance with government regulations.



# SAFE OPERATION

## FALL HAZARDS

Do not climb down from the platform when raised.

Do not climb on the boom.

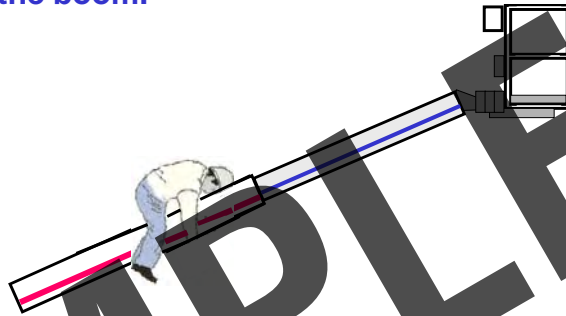

## COLLISION HAZARDS

Check work area for overhead obstructions. Be aware of crushing hazards. Always look in the direction of the platform movement.

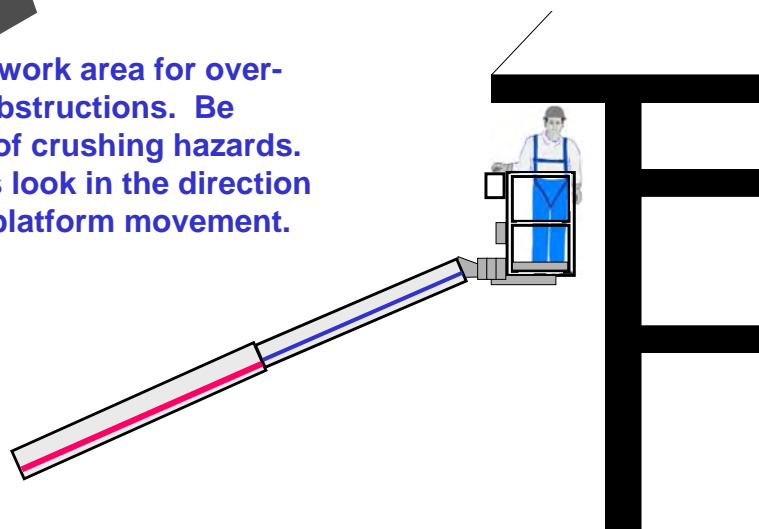

 HARD HAT TRAINING SERIES

 **HARD HAT**

## FALL HAZARDS

Being hit by another vehicle is the number one cause of being thrown out of the bucket. Always wear fall protection and direct traffic away from work area.

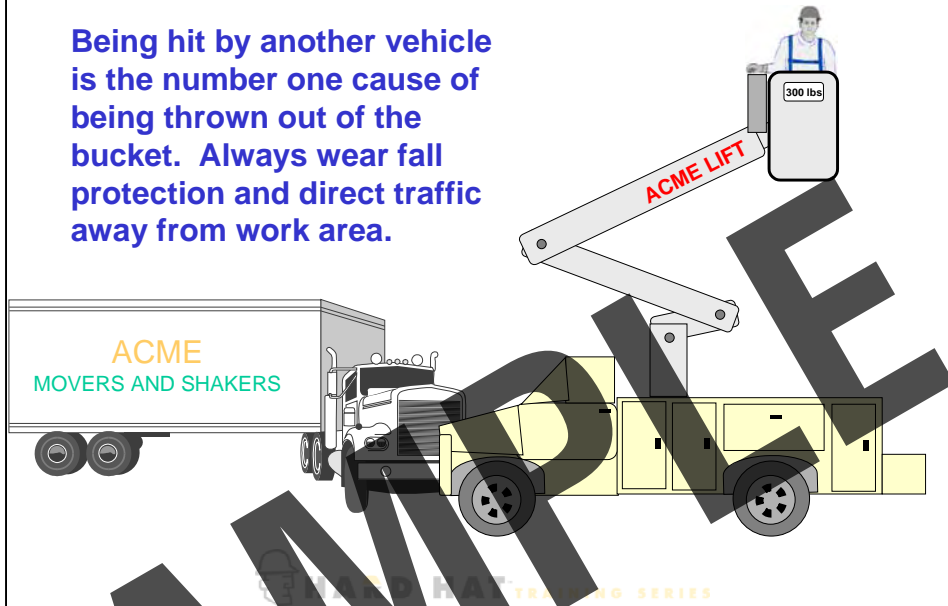

## COLLISION HAZARDS

Check work area for overhead obstructions. Be aware of crushing hazards. Always look in the direction of the platform movement.

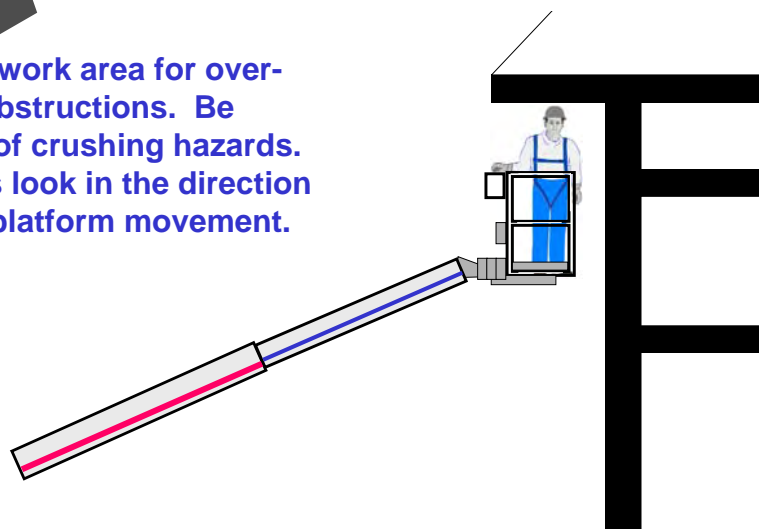

 HARD HAT TRAINING SERIES

 **HARD HAT**

# SAFE OPERATION

## COLLISION HAZARDS

Do not lower the boom unless the area below is clear of personnel and obstructions.

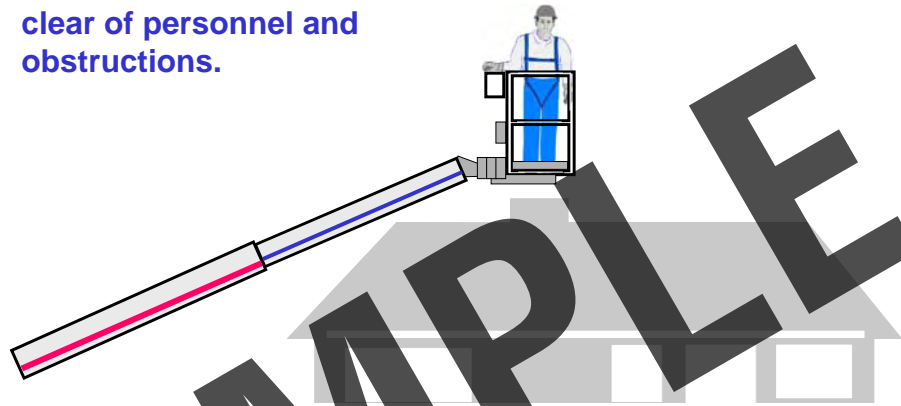

## COLLISION HAZARDS

Limit travel speed according to condition of ground surface, congestion, slope, location of personnel and any other factors.

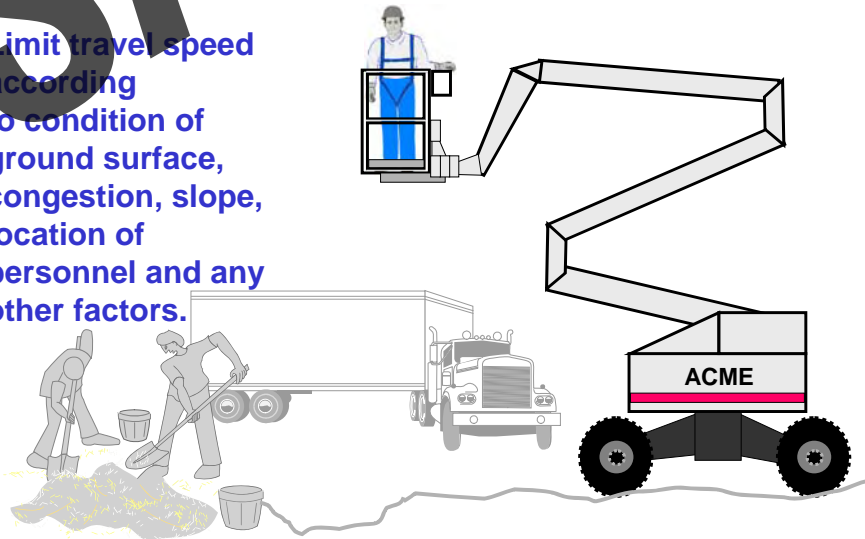

# SAFE OPERATION

## COLLISION HAZARDS

Take special care when working in or around trees. Controls should be guarded so as to avoid inadvertent contact by limbs or branches.

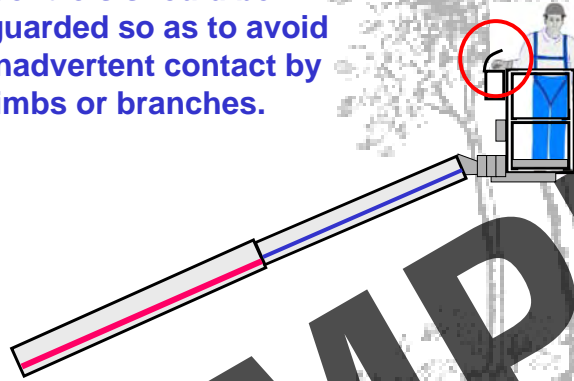

## SAFE OPERATION

**DON'T EXCEED THE MACHINE CAPACITY**

- Know the rated load of the machine
- Maximum load includes:
  - Personnel
  - Materials
  - Tools
- Distribute the load evenly

